

Growatt 3000TL3-S
Growatt 4000TL3-S
Growatt 5000TL3-S
Growatt 6000TL3-S
Growatt 7000TL3-S
Growatt 8000TL3-S
Growatt 9000TL3-S
Growatt 10000TL3-S
Growatt 11000TL3-S
Growatt 12000TL3
Growatt 12000TL3-S
Growatt 13000TL3-S
Growatt 15000TL3-S



Shenzhen Growatt New Energy Technology CO.,LTD
No.28 Guangming Road, Longteng Community,
Shiyan, Bao'an District, Shenzhen, P.R.China

T + 86 755 2747 1942
E service@ginverter.com
W www.ginverter.com

Installation & Operation Manual

Index

1 Information on this Manual

- 1.1 Documents use
- 1.2 Symbols Used
- 1.3 Glossary

2 Safety

- 2.1 Intended Use
- 2.2 Safety Precautions
- 2.3 Assembly Warnings
- 2.4 Electrical Connection Warnings
- 2.5 Operation Warnings
- 2.6 Symbols on the inverter

3 Product Description

- 3.1 Inverter overview
- 3.2 Type label
- 3.3 Size and weight
- 3.4 Transportation
- 3.5 Storage of Inverter
- 3.6 The advantage of the inverter

4 Unpacking

5 Installation

- 5.1 Safety instruction
- 5.2 Selecting the Installation Location
- 5.3 Installation guide
- 5.4 Electrical Connections
- 5.5 Grid Type

6 Commissioning

- 6.1 Commission the Inverter
- 6.2 Operation Modes
- 6.3 Country Setting and LCD Display
- 6.4 Double MPPT of the TL3-S
- 6.5 Communication

7 Start-Up and shut down the inverter

- 7.1 Start-Up the inverter
- 7.2 Shut down the Inverter

8 Maintenance and Cleaning

- 8.1 Cleaning the Inverter
- 8.2 Checking the DC Disconnect

9 Trouble shooting

- 9.1 Error Messages displayed on LCD
- 9.2 System fault
- 9.3 Inverter warning
- 9.4 Inverter fault

10 Decommissioning

- 10.1 Dismantling the Inverter
- 10.2 Packing the Inverter
- 10.3 Disposing of the Inverter

11 Specification

- 11.1 Specification of TL3-S
- 11.2 DC connector info
- 11.3 Torque Values
- 11.4 Spare Parts and Accessories

12 PV system installation

- 12.1 Single inverter
- 12.2 Multi inverters

13 Certificates

14 Contact

1 Information on this Manual

1.1 Documents use

1.1.1 Validity

This installation guide contains installation, commissioning, communication, trouble shooting. Information of Growatt TL3-S series inverters:

Growatt 3000TL3-S
Growatt 4000TL3-S
Growatt 5000TL3-S
Growatt 6000TL3-S
Growatt 7000TL3-S
Growatt 8000TL3-S
Growatt 9000TL3-S
Growatt 10000TL3-S
Growatt 11000TL3-S
Growatt 12000TL3
Growatt 12000TL3-S
Growatt 13000TL3-S
Growatt 15000TL3-S

With this installation guide, users are able to install and operate the inverters easily. This manual does not cover any details concerning equipment connected to the inverter. Store this manual where accessible at all times.

1.1.2 Target Group

This manual is for qualified persons who will operate, maintenance, service and repaired inverters.

1.1.3 Storage of the manual







Store this manual where it will be accessible at all times. We assume no liability for any damage caused by failure to observe these instructions. For possible changes in this manual, SHENZHEN GROWATT NEW ENERGY TECHNOLOGY CO.,LTD accepts no responsibilities to inform the users.

1.1.4 Additional Information

For further information on special topics in the download area at www.ginverter.com

1.2 Symbols Used

The following types of safety instructions and general information appear in this document as described below:

Symbol	Description
	Read the manual
 DANGER	DANGER indicates a hazardous situation which, if not avoided, will result in death or serious injury.
 WARNING	WARNING indicates a hazardous situation which, if not avoided, could result in death or serious injury.
 CAUTION	WARNING indicates a hazardous situation which, if not avoided, could result in death or serious injury.
 NOTICE	NOTICE indicates a situation which, if not avoided, could result in property damage.
 Information	Information that you must read and know to ensure optimal operation of the system.

1.3 Glossary

AC

Abbreviation for "Alternating Current"

DC

Abbreviation for "Direct Current"

Energy

Energy is measured in Wh (watt hours), kWh (kilowatt hours) or MWh (megawatt hours).

Power

Power is measured in W (watts), kW (kilowatts) or MW (megawatts). Power is an instantaneous value. It displays the power your inverter is currently feeding into the power distribution grid.

Power rate

Power rate is the ratio of current power feeding into the power distribution grid and the maximum power of the inverter that can feed into the power distribution grid.

Power Factor

Power factor is the ratio of true power or watts to apparent power.

PV

Abbreviation for photovoltaic

Wireless communication accessories (optional)

The external wireless communication technology is a radio technology that allows the inverter and other communication products to communicate with each other.

2.1 Intended Use

TL3-S series inverters are grid-tied inverters which convert DC current generated by PV modules into AC current and feed it into the public grid in three-phase. TL3-S series inverters are multi-string inverters with multi-MPP trackers, which mean they are able to connect to different PV module arrays.

Grid-tied PV system Overview:

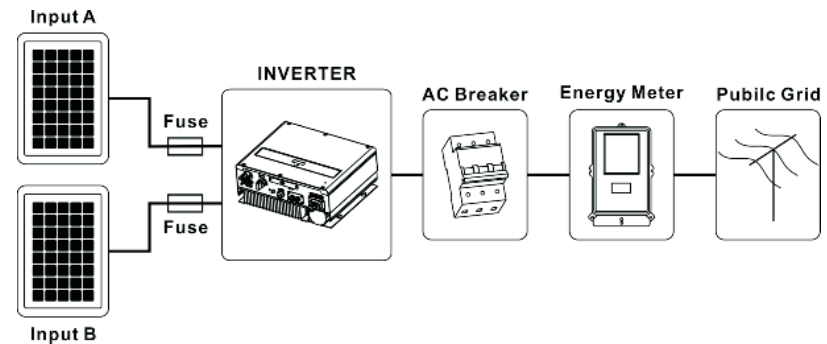

Fig1.1

The inverter may only be operated with a permanent connection to the public power grid. The inverter is not intended for mobile use. Any other or additional use is not considered as intended use. The manufacturer/supplier is not responsible for any damages resulting from unintended use. Damage caused by such unintended use is at the sole risk of the operator.

As drawings shown above, a complete Grid-tied PV system consists of PV modules, DC fuse or breaker (only for France, the other country is optional), PV inverters, public grid and other components. Moreover, PV inverters always act as key components.

When design a PV system contains any Growatt inverters, the system designing software "ShineDesign" (download from site: www.ginverter.com) will provide adequate supports.

PV modules Capacitive Discharge Currents

PV modules with large capacities relative to earth, such as thin-film PV modules with cells on a metallic substrate, may only be used if their coupling capacity does not exceed 2.2uF. During feed-in operation, a leakage current flows from the cells to earth, the size of which depends on the manner in which the PV modules are installed (e.g. foil on metal roof) and on the weather (rain, snow). This "normal" leakage current may not exceed 100mA due to the fact that the inverter would otherwise automatically disconnect from the electricity grid as a protective measure.

2.2 Safety Precautions

The TL3-S series Inverter is designed and tested according to International safety requirements; however, certain safety precautions must be observed when installing and operating this inverter. Read and follow all instructions, cautions and warnings in this installation manual. If questions arise, please contact our technical services at +86 (0)755 2747 1942.

2.3 Assembly Warnings



WARNING

- The inverter may only be operated with a permanent connection to the public power grid. The inverter is not intended for mobile use. Any other or additional use is not considered the intended use. The manufacturer/supplier is not liable for damage caused by such unintended use. Damage caused by such unintended use is at the sole risk of the operator.
- Prior to installation, inspect the unit to ensure absence of any transport or handling damage, which could affect insulation integrity or safety clearances; failure to do so could result in safety hazards.
- Unauthorized removal of necessary protections, improper use, incorrect installation and operation may lead to serious safety, shock hazards or equipment damage. In order to minimize the potential of a shock hazard due to hazardous voltages, cover the entire solar array with dark material prior to connecting the array to any equipment.



CAUTION

- Grounding the PV modules: Comply with the local requirements for grounding the PV modules and the PV generator.
- We recommend connecting the generator frame and other electrically conductive surfaces in a manner which ensures continuous conduction and ground these in order to have optimal protection of the system and personnel.

2.4 Electrical Connection Warnings



DANGER

- Some components in the inverter are live. Touching live components can result in serious injury or death.
- Danger to life due to high voltages in the inverter
 - All work on the inverter may be carried out by qualified personnel only.
 - The appliance is not to be used by children or persons with reduced physical, sensory or mental capabilities, or lack of experience and knowledge, unless they have been given supervision or instruction.
- Children are forbidden to play around the inverter.



WARNING

- Make all electrical connections (e.g. conductor termination, fuses, PE connection, etc.) in accordance with prevailing regulations. When working with the inverter powered on, adhere to all prevailing safety regulations to minimize risk of accidents.
- The inverter may only be operated with PV generators (modules and cabling) with protective insulation. Do not connect any source other than PV modules to the inverter.
- Systems with inverters typically require additional control (e.g., switches, disconnects) or protective devices (e.g., fuse, circuit breaker) depending upon the prevailing safety rules.



CAUTION

- The Growatt inverter is to be used solely to feed solar energy converted photovoltaically into the public grid. The inverter is suitable for mounting indoors and outdoors.
- You can use the AC current generated as follows:

House grid:	Energy flows into the house grid. The consumers connected, for example, household devices or lighting, consume the energy. The energy left over is fed into the public grid. When the UE series inverters do not generate any energy, e.g., at night, the consumers which are connected are supplied by the public grid. The energy displayed on the LCD of inverter is for reference only. When energy is fed into the public grid, the energy meter spins backwards.
Public grid:	Energy is fed directly into the public grid. The UE series inverters need install a separate energy meter. The energy produced is compensated at a rate depending on the electric power company.

2.5 Operation Warnings



WARNING

- Ensure all covers and doors are closed and secure during operation.
- Although designed to meet all safety requirements, some parts and surfaces of Inverter are still hot during operation. To reduce the risk of injury, do not touch the heat sink at the back of the PV-Inverter or nearby surfaces while Inverter is operating.
- Incorrect sizing of the PV plant may result in voltages being present which could destroy the inverter.
 - Turn the rotary switch of the DC Disconnect to the Off position ; immediately.
 - Contact installer.

- > All operations regarding transport, installation and start-up, including maintenance must be operated by qualified, trained personnel and in compliance with all prevailing codes and regulations.
- > Anytime the inverter has been disconnected from the power network, use extreme caution as some components can retain charge sufficient to create a shock hazard; to minimize occurrence of such conditions, comply with all corresponding safety symbols and markings present on the unit and in this manual. In special cases, there may still be interference for the specified application area despite maintaining standardized emission limit values (e.g. when sensitive equipment is located at the setup location or when the setup location is near radio or television receivers). In this case, the operator is obliged to take proper action to rectify the situation.
- > Possible damage to health as a result of the effects of radiation!
 - Do not stay closer than 20 cm to the inverter for any length of time.



CAUTION

2.6 Symbols on the inverter

Symbol	Explanation
	Electrical voltage!
	Risk of burns!
	Point of connection for grounding protection.
	Operation after 5 minutes
	Direct Current (DC)
	Alternating Current (AC)
	CE mark. The inverter complies with the requirements of the applicable EC guidelines.
	EU waste electrical and electronic equipment (WEEE) label
	Read the manual

3.1 Inverter overview

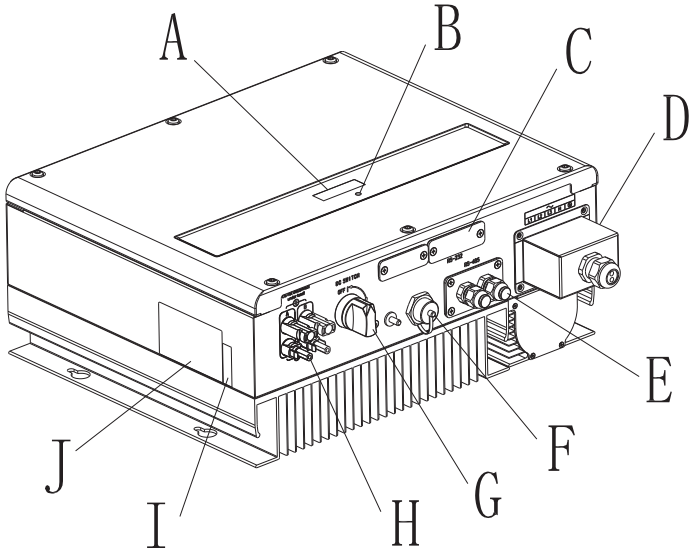

Position	Description
A	LCD
B	LED
C	Rs232 & DIP switch for RS485 configuration and External communication accessories power
D	AC output
E	RS 485
F	DRM PORT(Only for Australia)
G	DC switch
H*	PV input terminals
I	Series Number
J	Type label

* 3000-6000TL3-S & 7000-11000TL3-S & 12000TL3 2 pairs, 12000-15000TL3-S 3 pairs.

Symbol on the inverter

Symbol	Description	Explanation	
knock here ○	Tap symbol	Indicates display operation (see Section 6).	
STATUS ○ <small>Normal Fault</small>	Inverter state symbol	Green/constant	Operation
		Red/constant	Fault
		Red/flashing	Software update

3.2 Type label

The type labels provide a unique identification of the inverter (The type of product, Device-specific characteristics, Certificates and approvals). The type labels are on the right-hand side of the enclosure.

The Certificate Number is just for SAA.

Growatt PV Grid Inverter	
Model Name	Growatt xxxxxx
Max. DC voltage	XXX Vdc
DC voltage range	160V-XXX Vdc
MPP voltage range	xxxV-xxx Vdc
PV In	2 * xxxA
Max. apparent power	xxx kVA
Nominal output current	xxx A * 3
Nominal output voltage	311/110V 230 /400 V
AC Frequency	50/60Hz
Power Factor	0.8leading-0.8lagging
Safety Level	Class I
Protection Degree	IP65
Operation Ambient Temperature	-25°C - +60°C
Certificate Number	*****

3.3 Size and weight

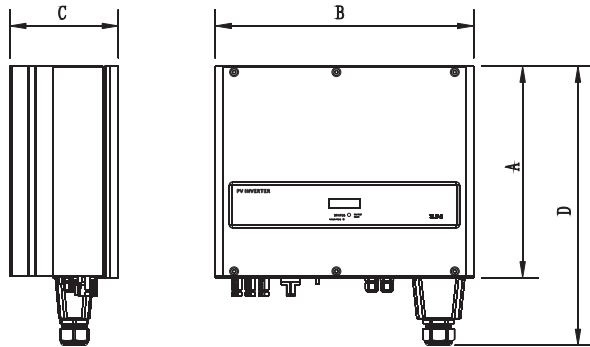

A(mm) B(mm) C(mm) D(mm) Weight(kg)

3000-6000 TL3-S	393	480	200	473	21.2
7000-110000 TL3-S	393	480	200	473	22
12000-150000 TL3-S	393	480	200	473	23.5

3.4 Transportation

The inverter is thoroughly tested and inspected strictly before delivery. Our inverters leave our factory in proper electrical and mechanical condition. Special packaging ensures safe and careful transportation. However, transport damage may still occur. The shipping company is responsible in such cases. Thoroughly inspect the inverter upon delivery. Immediately notify the responsible shipping company if you discover any damage to the packaging which indicates that the inverter may have been damaged or if you discover any visible damage to the inverter. We will be glad to assist you, if required. When transporting the inverter, the original or equivalent packaging should be used, and the maximum layers for original carton is four, as this ensures safe transport.

3.5 Storage of Inverter

If you want to storage the inverter in your warehouse, you should choose an appropriate location to store the inverter.

- The unit must be stored in original package and desiccant must be left in the package.
- The storage temperature should be always between -25°C and +60°C. And the storage relative humidity should be always between 0 and 95%.
- If there are lots of inverters need to be stored, the maximum layers for original carton is four.
- After long term storage, local installer or service department of manufacturer should perform a comprehensive test before installation

Information

After long term storage, the Real Time Clock of the inverter maybe not correct, it will cause the Energy produced today (E_{day}) error, you need to set the time and date, refer to 6.3.5 setting inverter time and date.

3.6 The advantage of inverter

The features of inverter are below:

- Dual independent MPP trackers
- Integrated DC disconnect switch
- RS485/Wifi /RF/GPRS
- Wide PV voltage range: 160V~1000/1100V
- The maximum efficiency is 98.3%
- IP65 environmental protection
- Easy to install

4 Unpacking

Before opening the packing box of UE series inverter, please note that whether there are any visible external damages.

Once open the packing box, please check the delivery for completeness and for any visible external damages of the inverter. If there are anything damaged or missing, please contact your dealer. Complete delivery should contain as follows.

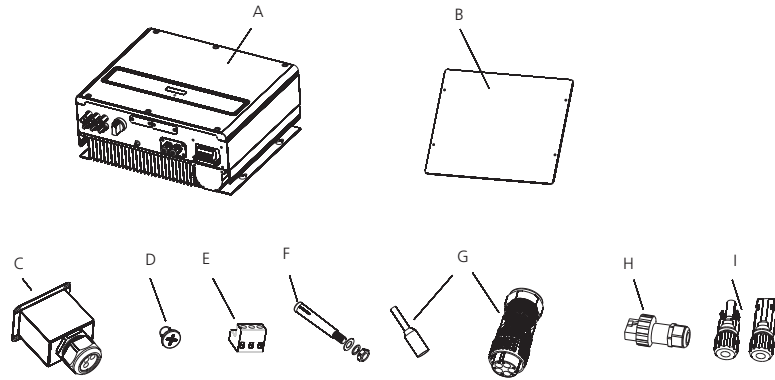

Item	Number	Description
A	1	Inverter
B	1	Quick installation guide
C	3	Cable gland for AC connection
D	4	M4 cross recessed countersunk head screws
E	1	RS485 terminals
F	4	Expansion bolt
G	5/1	Cord End Terminal/AC connector
H	1	RJ 45 PLUG (Only for Australia)
I*	2/3	PV connectors
--	1	User manual (not show in the picture)

* 3000-11000TL3-S & 12000TL3-S 2 Pairs

* 12000TL3-S & 15000TL3-S 3 Pairs



Information

Though the packaging box of TL3-S is durable, please treat the packing box gently and avoid dispose the packing box.

Installation 5

5.1 Safety instruction



Danger to life due to fire or explosion

- > Despite careful construction, electrical devices can cause fires.
- > Do not install the inverter on easily flammable materials and where flammable materials are stored.



Risk of burns due to hot enclosure parts

- > Mount the inverter in such a way that it cannot be touched inadvertently.



Possible damage to health as a result of the effects of radiation!

In special cases, there may still be interference for the specified application area despite maintaining standardized emission limit values (e.g. when sensitive equipment is located at the setup location or when the setup location is near radio or television receivers). In this case, the operator is obliged to take proper action to rectify the situation.

Never install the inverter near the sensitive equipment (e.g. Radios, telephone, television, etc)

Do not stay closer than 20 cm to the inverter for any length of time unless it is absolutely necessary.

We assume no responsibility for compliance to EMC regulations for the complete system.

- > All electrical installations shall be done in accordance with the local and national electrical codes. Do not remove the casing. Inverter contains no user serviceable parts. Refer servicing to qualified service personnel. All wiring and electrical installation should be conducted by a qualified service personnel.
- > Carefully remove the unit from its packaging and inspect for external damage. If you find any imperfections, please contact your local dealer. Be sure that the inverters connect to the ground in order to protect property and personal safety.
- > The inverter must only be operated with PV generator. Do not connect any other source to it.
- > Both AC and DC voltage sources are terminated inside the PV Inverter. Please disconnect these circuits before servicing.
- > This unit is designed to feed power to the public power grid (utility) only. Do not connect this unit to an AC source or generator. Connecting Inverter to external devices could result in serious damage to your equipment.

- When a photovoltaic panel is exposed to light, it generates a DC voltage. When connected to this equipment, a photovoltaic panel will charge the DC link capacitors.
- Energy stored in this equipment's DC link capacitors presents a risk of electric shock. Even after the unit is disconnected from the grid and photovoltaic panels, high voltages may still exist inside the PV-Inverter. Do not remove the casing until at least 5 minutes after disconnecting all power sources.
- Although designed to meet all safety requirements, some parts and surfaces of Inverter are still hot during operation. To reduce the risk of injury, do not touch the heat sink at the back of the PV-Inverter or nearby surfaces while Inverter is operating.

5.2 Selecting the Installation Location

5.2.1 This is guidance for installer to choose a suitable installation location, to avoid potential damages to device and operators.

- 1) The wall selected to install the inverter must be strong and firm enough to support and bear the weight of the inverter for a long period time.
- 2) The location selected must be suitable for inverters' dimension. (Refer to 3.3 Dimensions and Fig.5.2 Required Clearances)
- 3) Do not install the inverter on structures constructed of flammable or thermo labile materials.
- 4) Never install the inverter in environment of little or no air flow, nor dust environment.
- 5) The Ingress Protection rate is IP65 which means the inverter can be installed outdoors and indoors.
- 6) Do not expose the inverter to direct sunlight, in order to avoid the power and efficiency derating caused by excessive heating.
- 7) The ambient temperature of the inverter should be $-25^{\circ}\text{C} \sim +60^{\circ}\text{C}$.
- 8) The installation location must be freely and safely to get at all times.
- 9) Vertically installation and make sure the connection of inverter must be downwards. Never install horizontal and avoids forward and sideways tilt. (Refer to drawings below)

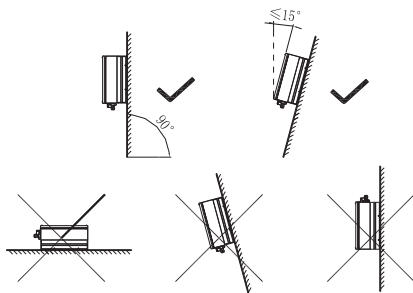

Fig5.1

- 10) Notice the minimum clearances of the inverter. (Refer to 3.3 Dimensions and Fig.5.2 Required Clearances).

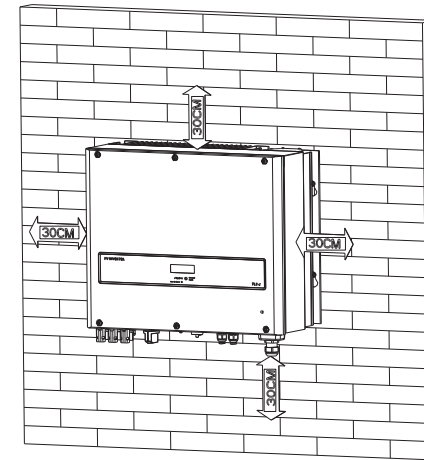

Fig5.2

- 11) Do not install the inverter near television antenna or any other antennas and antenna cables.
- 12) Do not install the inverter in living area, the noise caused by the machine may affect on daily life.
- 13) For security reasons, don't install the inverter in place where the children can reach.

5.3 Installation guide

5.3.1 Mounting Expansion Bolt



In order to avoid electrical shock or other injury, inspect existing electronic or plumbing installations before drilling holes.

To mount the inverter on the wall, we should mount expansion bolt to the wall firmly first.

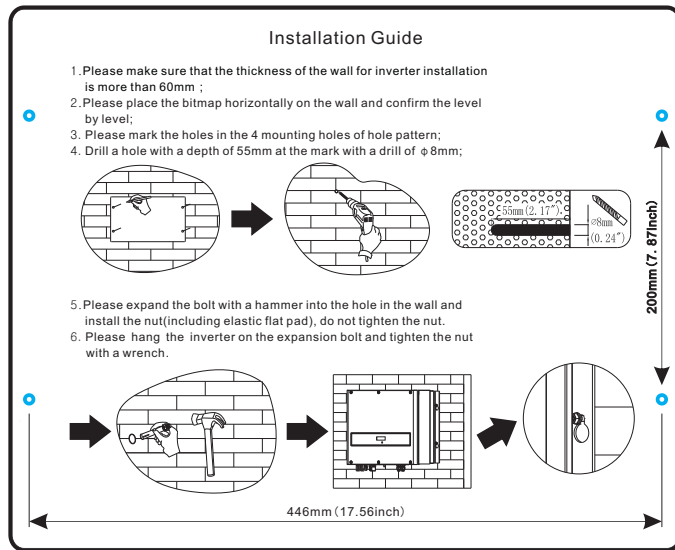

Fig5.3

Hint: Data units in mm
Steps:

- Drill four holes for expansion bolt use the Fix Hole Paper as template.
- Fix the mounting expansion bolt on the wall as the figures shown below, combine four expansion bolt with four M6 nuts. Refer to Fig 5.4.

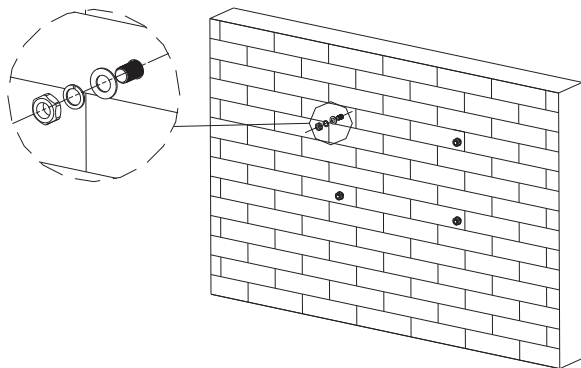

Fig5.4

5.3.2 Mounting Inverter



Falling equipment can cause serious or even fatal injury, never mount the inverter on the bracket unless you are sure that the mounting frame is really firmly mounted on the wall after carefully checking.

After expansion bolt is firmly mounted on the wall, then mount the inverter on expansion bolt.

- Rise up the inverter a little higher than expansion bolt. Considering the weight of inverter, you need to hang on the inverter. During the process please maintain the balance of the TL3-S.
- Hang the inverter on the expansion bolt.
- After confirming the inverter is stuck on expansion bolt, fasten four M6 screws. Refer to Fig 5.5.

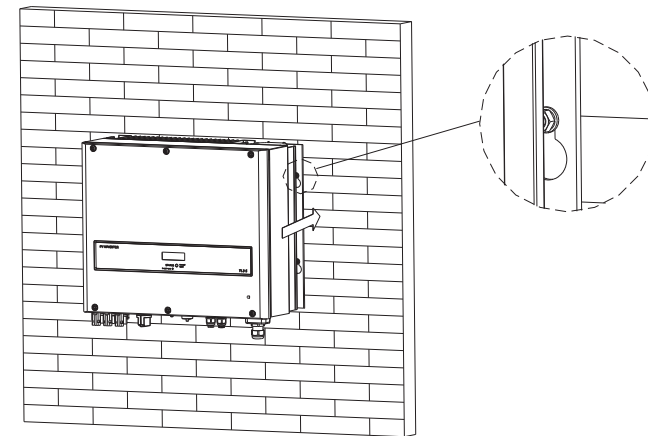

Fig5.5

- Connection of a second protective conductor
In some installation countries, a second protective conductor is required to prevent a touch current in the event of a malfunction in the original protective conductor. For installation countries falling within the scope of validity of the IEC standard 62109, you must install the protective conductor on the AC terminal with a conductor cross-section of at least $10 \text{ mm}^2 \text{Cu}$. Or Install a second protective conductor on the earth terminal with the same cross-section as the original protective conductor on the AC terminal. This prevents touch current if the original protective conductor fails.

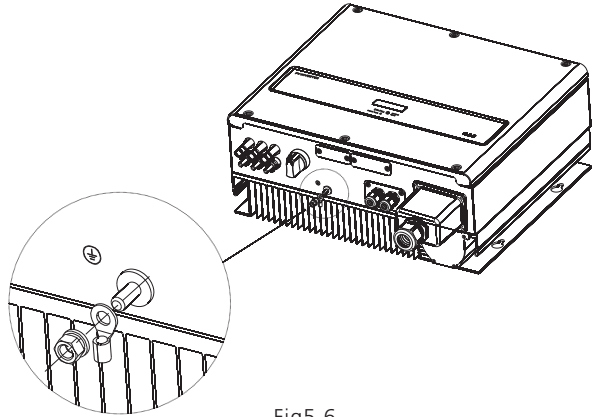

Fig5.6

5.3.3 Installation layout

i
Information

Avoid exposing inverter to direct sunlight, rain or snow to extend the inverter service life despite the IP65 protection degree. Exposure to the sunlight may cause additional internal heating which will cause power derating.

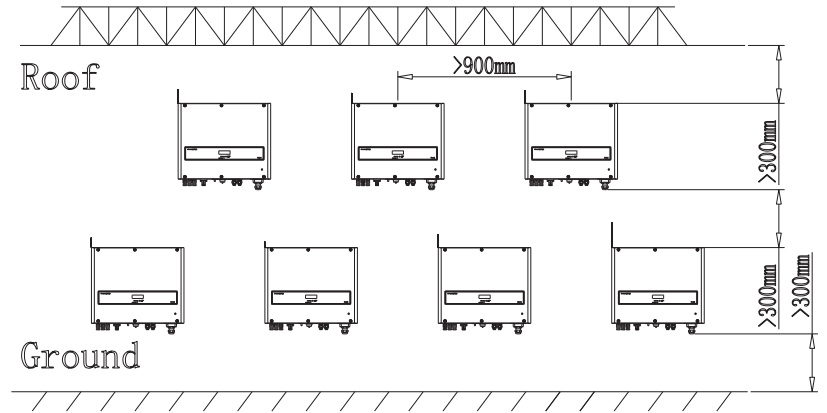

Fig 5.8



Fig5.7

More than one inverter need to be installed, the dimensions below should be considered.

Recommend awning installation, the purpose is to extend the inverter service life and reduce the power derating of the inverter. The dimension of the awning, refer to Fig 5.9.

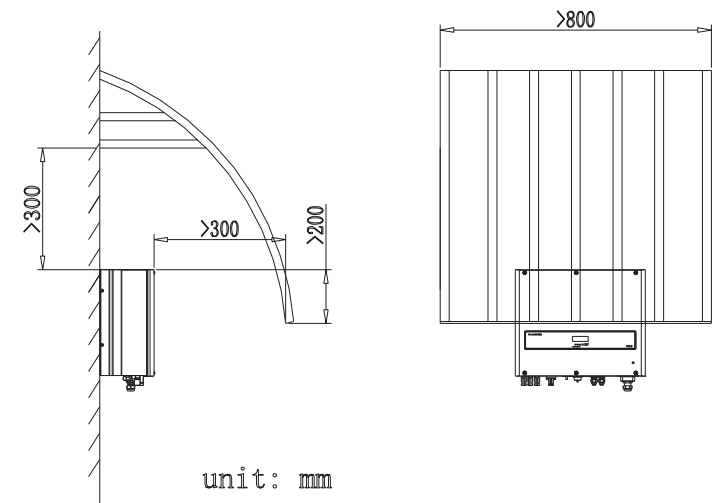

unit: mm

Fig 5.9

5.4 Electrical Connections

5.4.1 Safety



Danger to life due to lethal voltages!
High voltages which may cause electric shocks are present in the conductive parts of the inverter. Prior to performing any work on the inverter, disconnect the inverter on the AC and DC sides



Danger of damage to electronic components due to electrostatic discharge.

Take appropriate ESD precautions when replacing and installing the inverter.

5.4.2 Wiring AC Output

Conditions for the AC Connection

You must comply with the connection requirements of your utility operator. All usages must comply with the regulations.

Residual-current protective device

The inverter is equipped with an integrated universal residual-current monitoring unit. If the network operator stipulates a residual-current protective device, you must use a residual-current protective device that triggers in the event of a residual-current of 300 mA or more.

Load disconnection unit

You must install a separate three-phase miniature circuit-breaker or other load disconnection unit for each inverter in order to ensure that the inverter can be safely disconnected under load.

Measure the public grid voltage and frequency (Voltage: 400Vac; Frequency: 50Hz/60Hz; 3-Phase);

- Open the breaker between the PV inverter and utility;

Specification of AC breaker:

3000-4000TL3-S	10A/400V
5000-7000TL3-S	16A/400V
8000TL3-S	20A/400V
9000-12000TL3-S	25A/400V
15000TL3-S	32A/400V

Cable requirements:

Outside diameter of cable(mm)		18-25					
Conductor Cross section	Max. cable length(m)						
	3000TL3-S 4000TL3-S	5000TL3-S 6000TL3-S	8000 TL3-S	9000 TL3-S	10000 TL3-S	11000TL3-S 12000TL3-S	13000TL3-S 15000TL3-S
AWG14	38m	/	/	/	/	/	/
AWG12	60m	40m	31.5m	28m	25m	23m	17m
AWG10	/	64m	55m	44.5m	40m	36.5m	27m
AWG8	/	/	/	/	/	/	54m

Connection to the AC side terminal

1. The AC side terminals of the inverter are like the following figure, Fig. 6a, it is clear to confirm that 'L1, L2, L3' represents three live line output, 'N' represents neutral line and Ⓧ is grounding line.
2. The five cables should be put through the protection shell, as Fig. 6b, crimp five standard cables with Cord End Terminal. Tighten all screws. Refer to Fig. 6c.
3. Fasten the protection shell onto the bottom of the inverter, make sure the four screws are tightened, the completed appearance is like the below figure Fig. 6d.

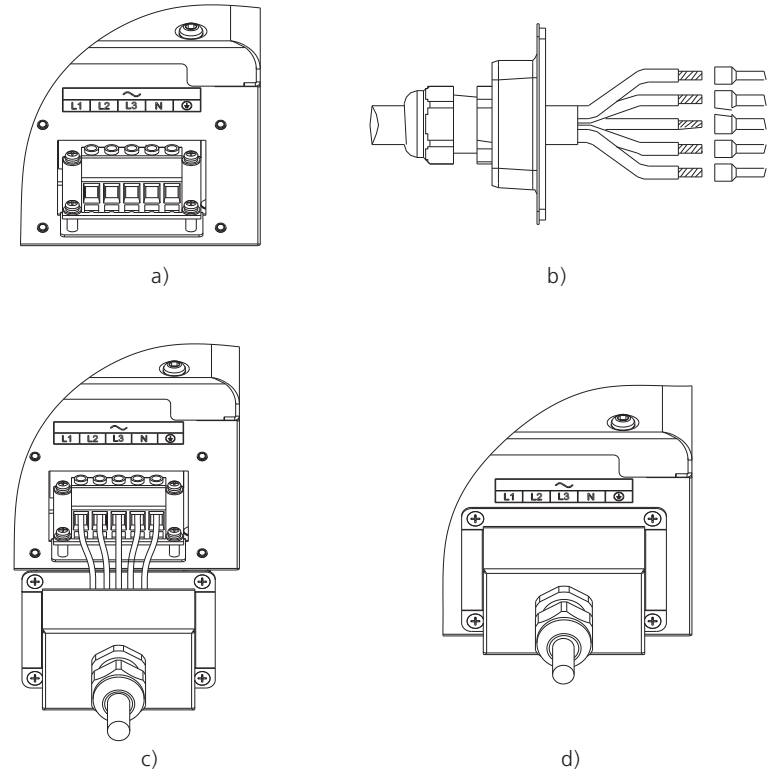

Fig 6

5.4.3 Wiring DC Input



Danger to life due to lethal voltages!

Before connecting the PV array, ensure that the DC switch and AC breaker are disconnect from the inverter. NEVER connect or disconnect the DC connectors under load.

Improper operation during the wiring process can cause fatal injury to operator or unrecoverable damage to the inverter. Only qualified personnel can perform the wiring work.



WARNING

Risk of damage to the inverter.
If the voltage of the PV modules exceeds the maximum input voltage of the inverter, it can be destroyed by the overvoltage. This will void all warranty claims.

Do not connect strings to the inverter that have an open-circuit voltage greater than the maximum input voltage of the inverter.

To reduce the risk of electric shock, avoid touching the live components and treat the terminals carefully.



Information

Please use the same brand male and female PV connectors.
Under any conditions the total circuit current should never exceed the Max. Current.



NOTICE

Excessive voltages can destroy the measuring device
Only use measuring devices with a DC input voltage range up to at least 1000 Vdc.

- 1 Check the connection cables of the PV modules for correct polarity and make sure that the maximum input voltage of the inverter is not exceeded.
- 2 The diagram drawing of DC side is shown as below, notice that the connectors are in paired (male and female connectors).

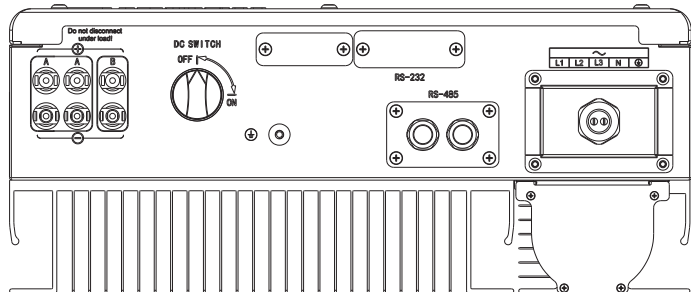

Fig 6.1

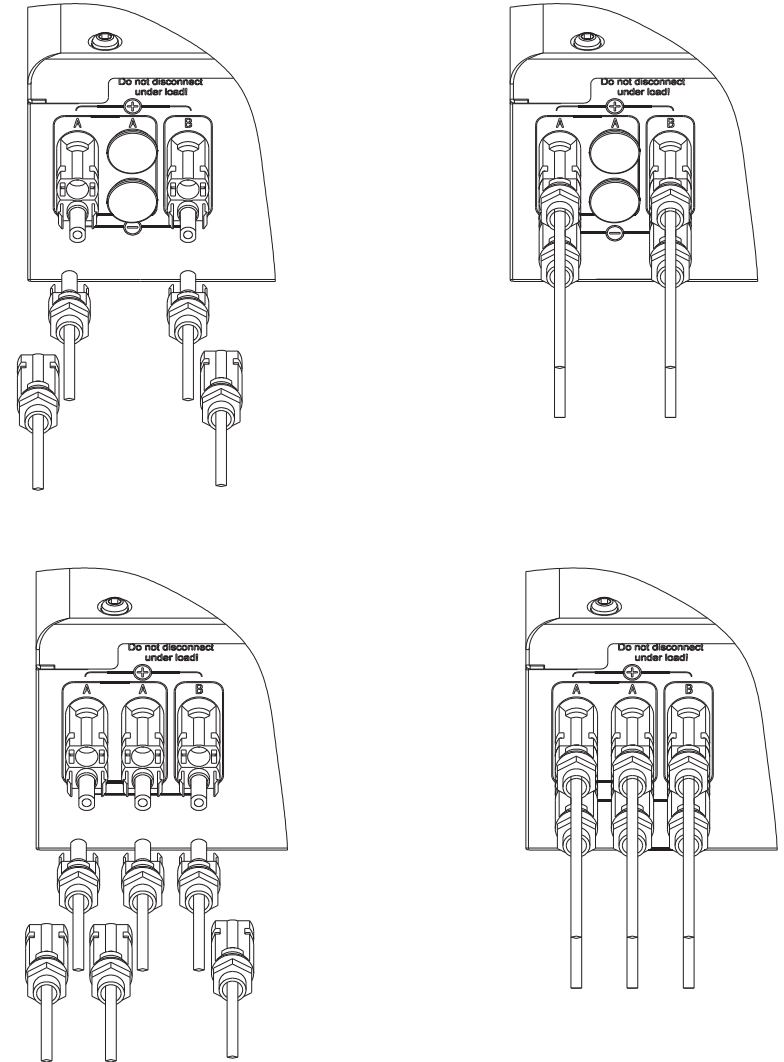

Fig 6.2

- 3 Check the assembled DC connectors for correct polarity and connect them to the inverter.
- 4 The maximum string currents are varying from different inverter types.

Model	Max.current
3000-6000TL3-S	11A/11A
7000TL3-S	11.5A/11.5A
8000-9000TL3-S	11.5A/11.5A
10000-11000TL3-S	13A/13A
12000TL3	11.5A/11.5A
12000-15000TL3-S	20A/10A

- 5 In order to seal the inverter, all unneeded DC inputs must be closed with sealing plugs:
Cable requirements:

Model	Diameter(mm)	Area(mm ²)	AWG
3000-15000TL3-S	1.63-2.05	2.0-4	14-12

5.4.4 Grounding

AC Grounding

The TL3-S series inverter must be connected to the AC grounding conductor of the power distribution grid via the ground terminal (PE).

PV Grounding

The grounding conductor in the framework of the PV array must be connected to the PV grounding conductor and the DC grounding conductor. The cross-section of the grounding conductor corresponds to the cross-section of the largest conductor in the DC system.

DC Grounding Conductor

A DC grounding conductor may be required by the Authority Having Jurisdiction (AHJ). Use the terminal block for the PV grounding conductor and DC grounding conductor.

Ground kit

If PV modules of the PV system require POSITIVE or NEGATIVE to connect to GROUND, the output of inverter should connect to grid with an isolating transformer. The connection method is below:

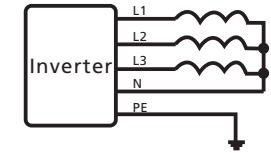

N of transformer should not be connected to PE.

5.5 Grid Type

5.5.1 Common grid type

Based on the local GRID standards, it may select different connection types. In the following you will find an overview of the most common type of grid structure.

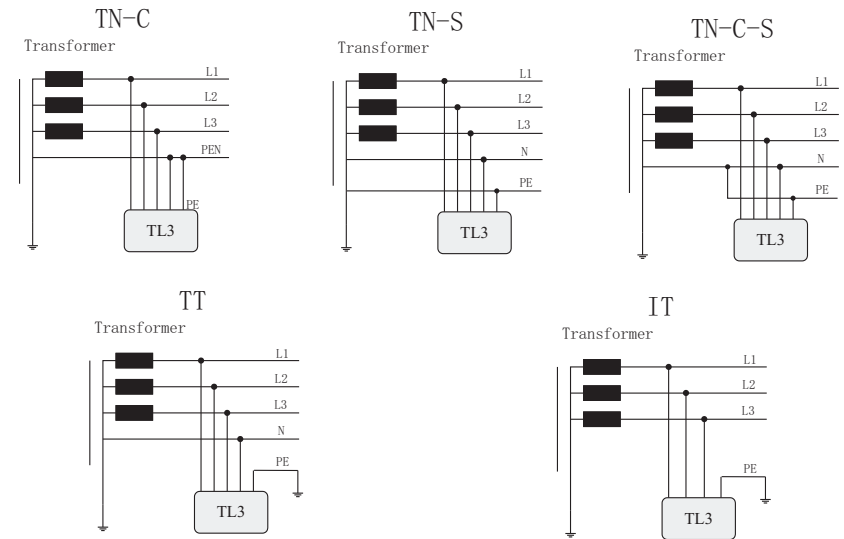

5.5.2 Compatibility Table

Grid type	TN-C grid	TN-S grid	TN-C-S grid	TT grid	IT grid
3000-15000TL3-S	yes (N and PE of inverter both should connect to PEN of grid.)	yes	yes	yes, if UN-PE < 30V	yes, if UN-PE < 30V

6 Commissioning

6.1 Commission the Inverter

- 1) Remove all covers from the PV array.
- 2) Check the PV and AC voltage.
- 3) Plug in the PV input.
- 4) Turn the DC Disconnect to position "I".
- 5) If the inverter is connected with PV panel arrays and the input voltage is higher than 160Vdc, while the AC grid is not connected yet, LCD will display messages in order as below:
 - Company info → Basic info → State info
 - The LCD will display " AC V outage " at State info and the LED turns red.
 - Please check all information on the LCD, operate by knocks you will see the different parameters.
 - Single knock to Light the backlight → State info (single knock) Input info → (single knock) Output info

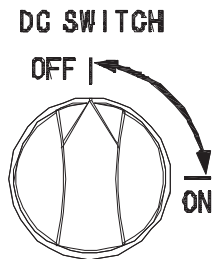

- 6) Turn on the AC breaker between inverter and grid, the system will operate automatically.
- 7) Under normal operating conditions, the LCD displays 'Power: xx.xx Kw' at State info, this is the power feed into grid. The LED turns green.
- 8) Check the time and date of inverter as follow: Single knock to Light the backlight → State info (Thrice knock) → Inverter info (single knock) → System Time(double knock), if they are not correct, please set them, refer to 6.3.5 setting inverter time and date.
- 9) Finish commissioning.

6.2 Operation Modes

Normal Mode

In this mode, the inverter works normally and LED turns green.

- Whenever the DC voltage is higher than 200Vdc, inverter converts power to grid
- Whenever the DC voltage is lower than 180Vdc, the inverter will work in waiting status and attempt to connect the grid. In waiting state the inverter consumes just power generated by the PV panel to monitor the internal system.

Notes: The inverter starts up automatically when DC power from the PV panel is sufficient.

Fault Mode

The internal intelligent controller can continuously monitor and adjust the system status. If inverter finds any unexpected conditions such as system fault and inverter fault, the fault information will be displayed on the LCD. In fault mode the LED turns red.

- Notes: a) Detailed fault information refers to Chapter 9 Trouble shooting.
b) When PV Isolation error occurred in SAA safety standard, the buzzer will give an alarm every fifteen seconds.

Shutdown Mode

Inverters automatically stop running during periods of little or no sunlight. In shutdown mode the inverters take no power from the grid and panel, and the LCD and LED turns off.

Notes: If the PV string DC voltage is too low, the inverter will also turn to Shutdown Mode.

Derating mode

When AC frequency is higher than 50.3Hz(settable), the inverter will derate its output power according to the rule.

When user set the output limit command to the inverter, the inverter will also limit the output according to the setting. In this derating mode, the LCD will show "DERATING".

6.3 Country Setting and LCD Display

In the lower right corner of inverter there is the LCD display. We can check inverter running state, historical generation data, etc, on the LCD screen. Items displayed can be changed by knock; you can also change some inverter parameters by knock.

6.3.1 Location of the country setting DIP switch

The DIP switch is located on the left of the RS232 interface at the bottom of the inverter, as the figure below.

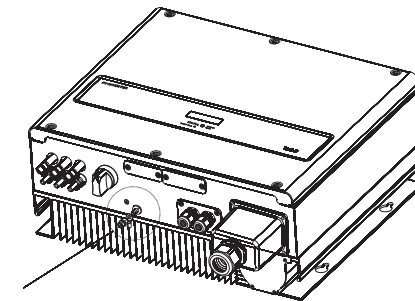

Country setting DIP switch



WARNING

To reduce the risk of electric shock, before selecting country, please turn off DC input and AC grid, than unscrew the dam-board of the DIP switch by appropriate tool.

The internal structure of the DIP switch is as the following figure:

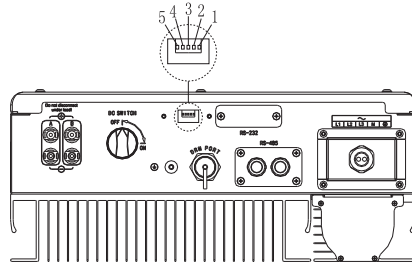

6.3.2 DIP switch option corresponding to the country



When you setting the DIP, you must turn off the AC breaker and DC breaker.

- After setting the DIP, please power on the inverter and check the model display. If the last character of the model name is corresponding to the country safety standard as the above table, it means your setting is successful.
- You should change the time displayed on the LCD of inverter to your local time after inverter starts up. **If the country is set incorrectly, please shut down the inverter and set again.**



Information

When the cables of AC side and DC side are all well connected, before commissioning, the country safety standard must be selected by the DIP switch. The DIP switch is composed of four-digit binary number PINS. The different combination of the four PINS can represent different inverter's model, which is corresponding to the local grid standard. Each small white PIN has two statuses, when set upward to 'ON', its value turns to '1', when set downward, its value turns to '0'. Concerning the matching of the PIN status and the country safety standard, please refer to the table below:

Switch to country table 6.3.1

DIP switch status	Country	Model display
	VDE 0126	GTXXXXXXX1
	G59-3	GTXXXXXXX2

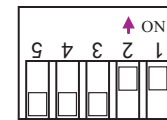

AS4777-Australia

GT0XXXXXX3

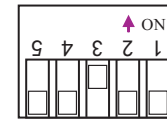

CEI 0-21

GT0XXXXXX4

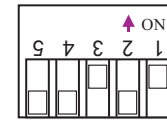

SP1699/Spain

GT0XXXXXX5

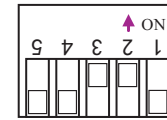

Greece

GT0XXXXXX6

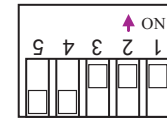

VDE-AR-N4105

GT0XXXXXX7

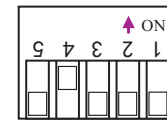

G83-2

GT0XXXXXX8

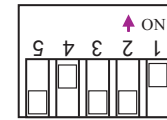

EN50438-Ireland

GT0XXXXXX9

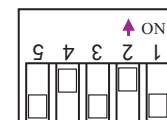

CQC

GT0XXXXXXA

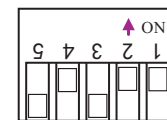

EN50438-Default

GT0XXXXXXB

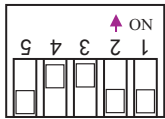

IEC61727&IEC62116

GT0XXXXXC

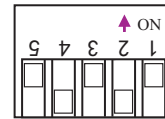

EN50438_Norway

GT1XXXXX5

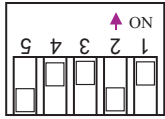

Belgium

GT0XXXXXD

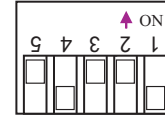

VFR2013

GT1XXXXX6

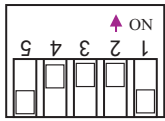

Thailand MEA

GT0XXXXXE

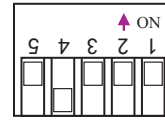

VFR2014

GT1XXXXX7

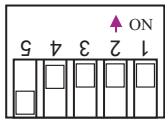

Thailand PEA

GT0XXXXXF

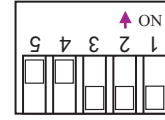

Reserved

GT1XXXXX8

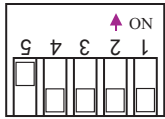

AS4777_Newzealand

GT1XXXXX0

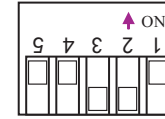

Reserved

GT1XXXXX9

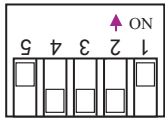

Reserved

GT1XXXXX1

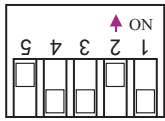

India

GT1XXXXX2

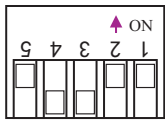

EN50438_Demark

GT1XXXXX3

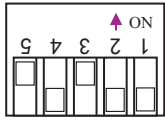

EN50438_Sweden

GT1XXXXX4

6.3.3 Display interface

Overall display interface introduction

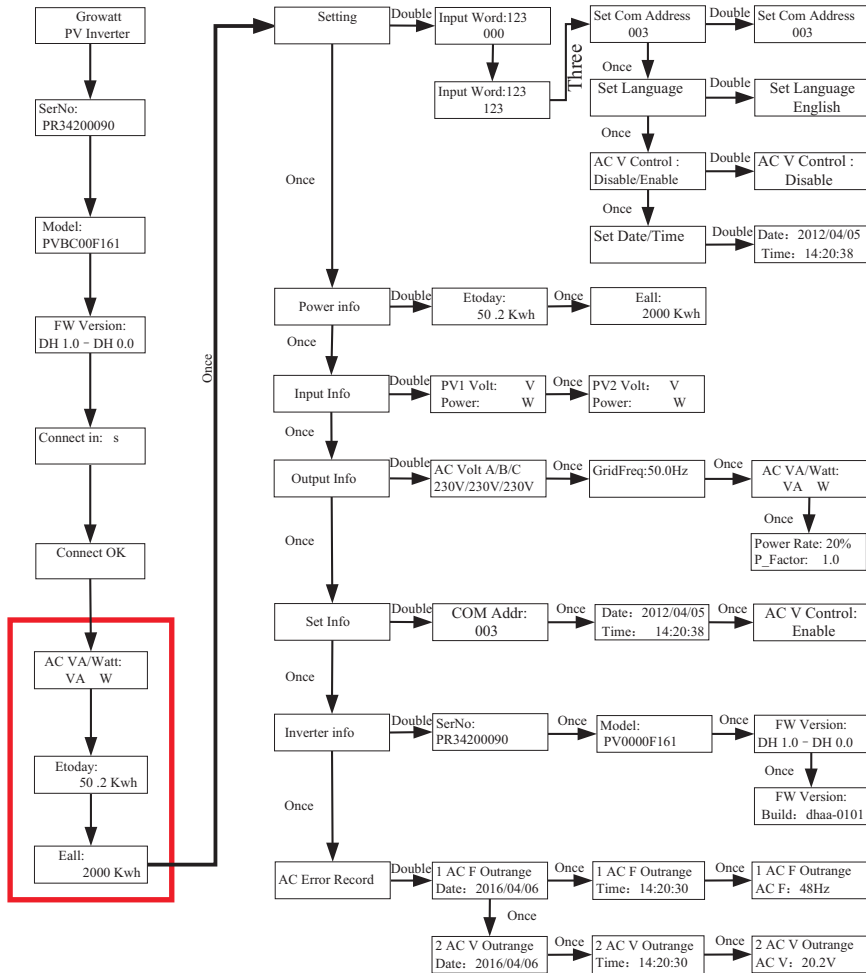

1. Once: Next page
2. Double: Enter
3. Three: Enter the setting
4. Four: Back to cycle display interface

Fig6.3 Overall display interface

Power on display

After inverter restarts, the background light will last for 2 seconds. You can check the inverter series number, model, firmware version. Refer Fig6.3.1.

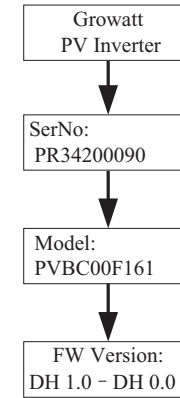

Fig6.3.1 Power on display

6.3.4 Operate by knock

Knock type and definition

The inverter can support four kinds of knock: single knock, double knock, third knock, Knock four times. Each kind of knock has different function. Refer to specified definition in Table 6.3.2.

Table 6.3.2 Knock definition list

Knock type	Definition
Single knock	Down
Double knock	Enter
Three knock	Make sure setting
Knock four times	Back to cycle display interface

Light backlight and single knock to check running information

Before light the backlight, the four types of knock functions are the same, which is just lighting the backlight. Note that the background lighting will automatically turn off if there is no knock detected in 10 seconds.

During cloudy days or in the area of low light, it's inconvenient for users to check inverter running information such as status, input data, output data, energy generated. In this case user can light the backlight and check those data by single knock, a single knock will switch LCD screen to a following interface.

6.3.5 Data checking and parameters setting

Cycle display

If you do not knock the enclosure lid, LCD display following information cycle by cycle. Refer Fig 6.3.3.

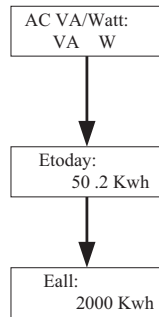

Fig 6.3.3 Cycle display

Parameters setting

Fig 6.3.4 is the setting information. Single knock, the Text will display the setting. Double knock, the Text will display "input123: 000". Single knock to go back Setting page. Double knock the enclosure lid ready to input password. Single knock to change value of first, double knock enter into next position. Konck three times when the bit was "123", it will go into Setting options.

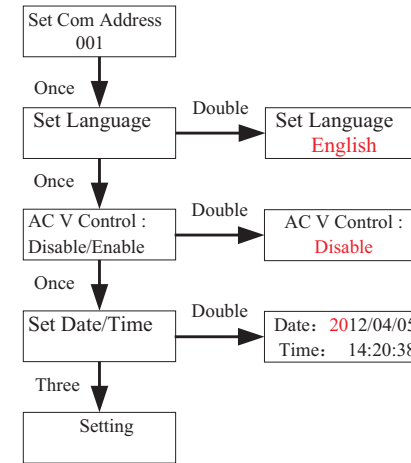
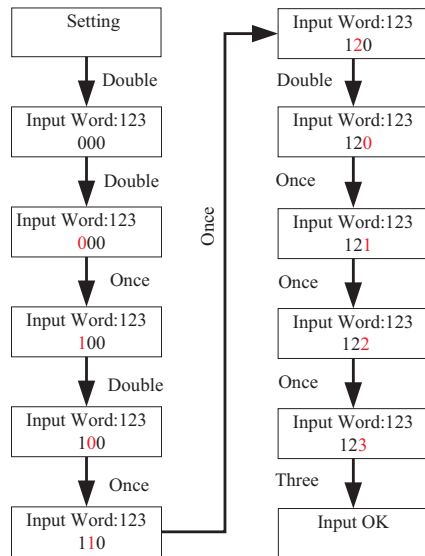

Fig 6.3.4 setting second level menu and its sub-menus

Setting language

To change inverter's displaying language, please select Setting->Set language, then LCD screen will display current language type, single knock to change current language, knock three times will save changes and displays "Set OK! Current Language English" Refer Fig 6.3.5. Knock four times to exit setting.

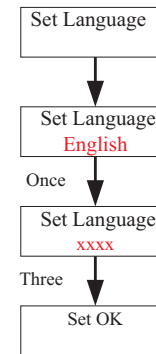

Fig 6.3.5 setting language

Please note in order to prevent disoperation, system language won't be change in second level menu "Set language", but it will be only if user saves save the choice by knock three times and LCD displays "Set OK!"

Setting inverter's COM address

When communicating with monitoring software or device, the software or device may regard inverter's COM address as communication address (Also may use inverter's serial number as communication address). The COM address could be assigned. The second level menu "Set COM Addr" of setting is to set inverter's COM address.

Setting COM address

Input password->Setting language->Set COM addr-> is the current address of inverter." Double knock the enclosure lid ready to input COM addr. Single knock to change COM Addr. Knock three times to save COM Addr. Refer Fig 6.3.6. Knock four times to exit setting.

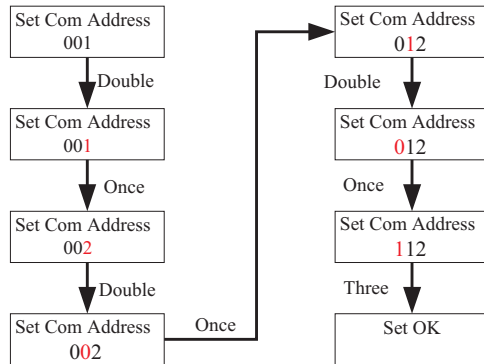

Fig 6.3.6 current COM Addr

Setting inverter time and date

Inverter provides a system clock; user must set the system time after installation, as the historical statistic data for a period were based on the clock. User can set the following time parameters: year, month, day, hour, minute.

Input password->Setting-> 2017/03/27 00:38 ->is the current time. Double knock to go into setting. Single knock to change time. Konck three times to save time. Knock four times to exit setting. Refer Fig 6.3.7.

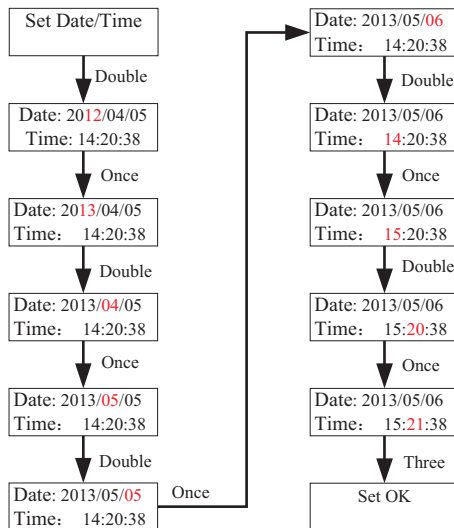
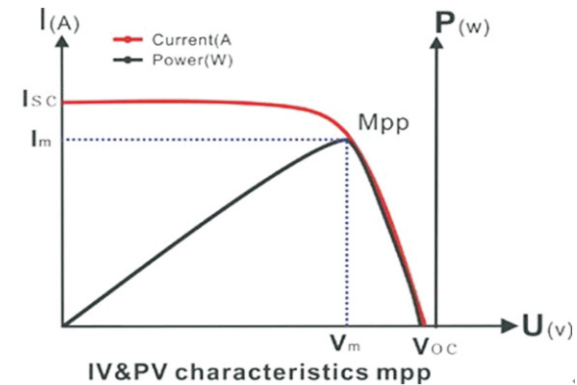

Fig 6.3.7 inverter date and time

6.4 Double MPPT of the TL3-S

The TL3-S includes dual input section to process two strings with independent MPPT, high speed and precise MPPT algorithm for real-time power tracking and energy harvesting, as well as transformerless operation for high performance, the max conversion efficiency is up to 98.3%. The wide input voltage range makes the inverter suitable to low power operation as well as the high power operation.

As the weather influence and the location of two MPPT PV arrays different, the power of the MPPT A inputs is different from the power inputs of the MPPT B at the same time, the TL3-S works at a non-symmetrical input status. But the MPPT algorithm of the inverter makes it tracking the maximum power point of every MPPT channel to improve the energy utilization of the PV arrays.



6.5 Communication

6.5.1 Using shinebus to set the information of the inverter or update firmware

About the software of shinebus and the usage of it please download from the web: www.growatt.com



The connecting diagram as follow:

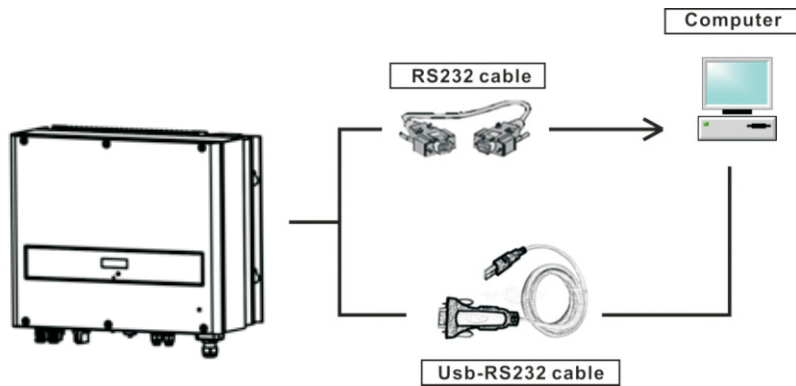

Active power control with a ripple control signal receiver

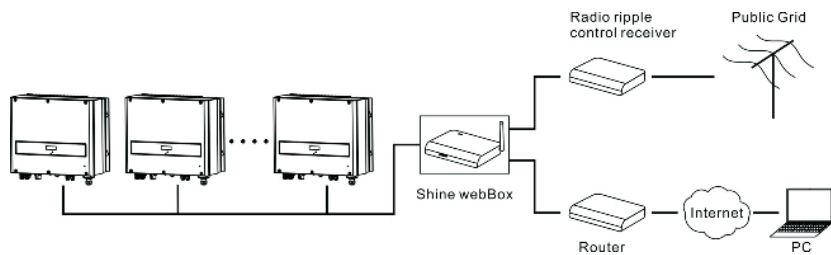

6.5.2 Monitor the inverters

The inverter provides RS485 interface and RS232 interface to communicate with remote PC or logger. User can monitor the inverter status via the following types of communication systems.

You can update firmware via RS232 or Rs485

Plan A:

- Through RS485 interface-Data logger-PC.

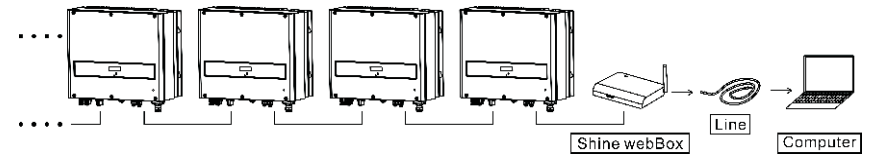

Information

If you plan to update firmware via RS485, please disconnect the monitor device.

- Through RS485 interface-RS485-232 /RS232 converter-PC.

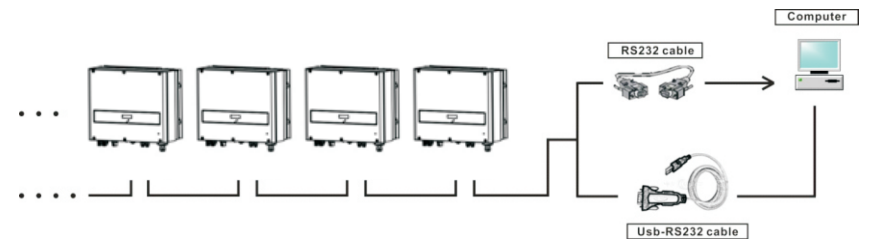

- Through RS232 interface- wireless module-Data logger-Internet.

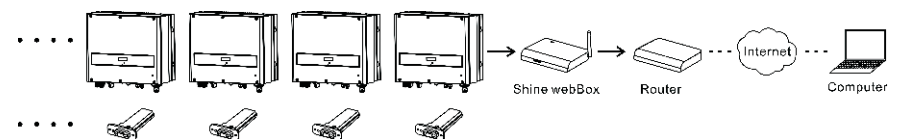

Plan B

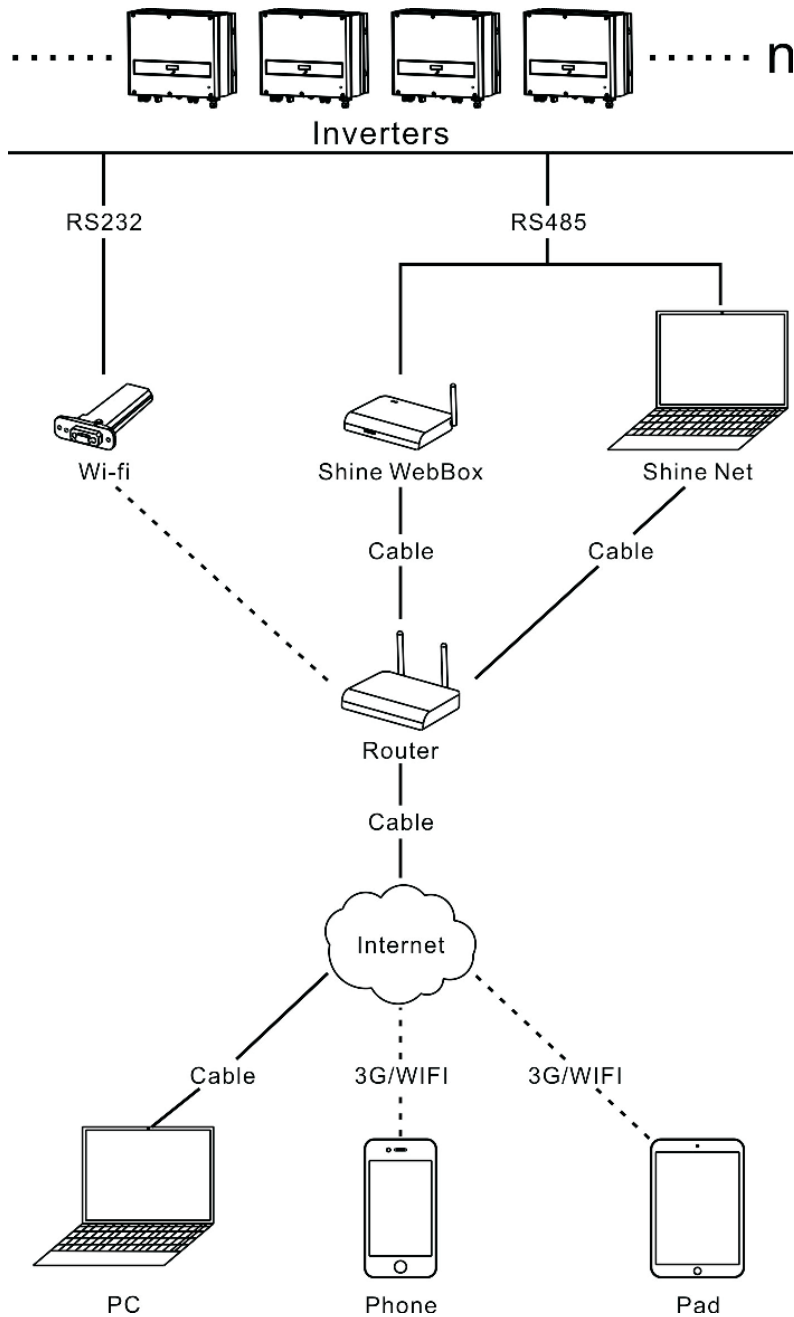

Information

When three phase inverter and single-phase inverter shared a RS485 communication line, the total length of which does not exceed 1km and device number should not be more than 32.

6.5.3 RS485 cable connection

Rs485 cable connection

Pin1----- TR-(B)	
Pin2----- Shielding layer or no connection	
Pin3----- TR+(A)	

Definitions of RS485 PLUG (standard) as follows:

Pin1----- TR-(B)	
Pin2----- Shielding layer or no connection	
Pin3----- TR+(A)	

1. Please loosen four screws, take down the RS485 waterproof cover from inverter. If you don't choose RS485 as communication method, keep it on the inverter.

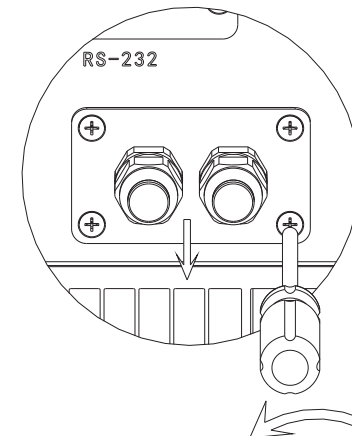

2. Slightly loosen the swivel nut, remove the filler-plug from the M16 cable gland.

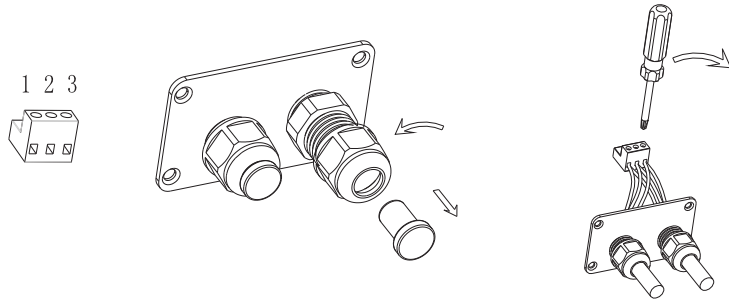

3. Make the cable through the hole of cable gland and put the cable into the Rs485 terminals, fix all cables with screwdriver ('1'to' T/R-(B)', '3'to' T/R+(A)', '2' to the shielding layer or no connection). The type of cable is recommended as STP, FTP,ASTP.



Information

Pull cables outwards to confirm whether they are installed firmly

4. Plug in two terminals. Cover the fix board.

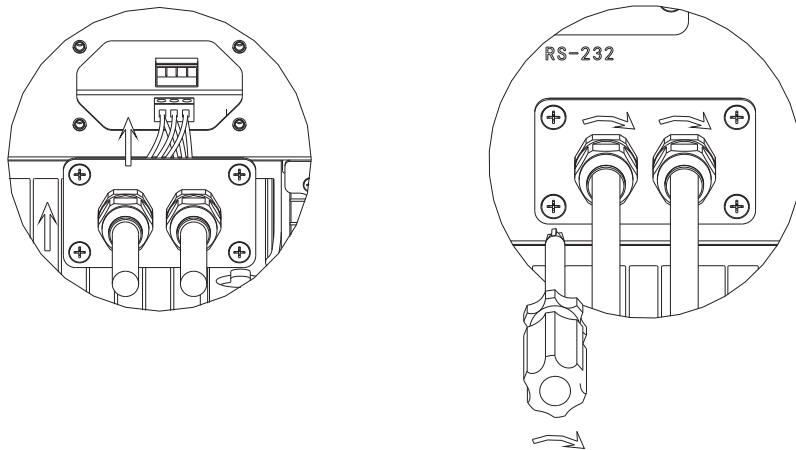

Information

Tighten 4 pcs screws first, then tighten cable gland.

5. Tighten 4pcs screws and cable gland.

Note:

1) As to the connection between inverters, please refer to the following figure.

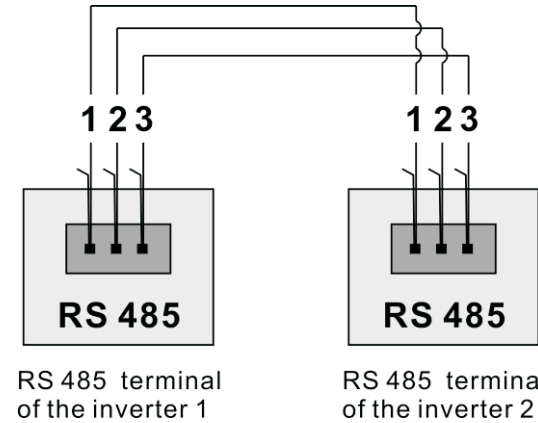

2) As to the connection between inverter and ShineWebBox, please refer to the following figure.

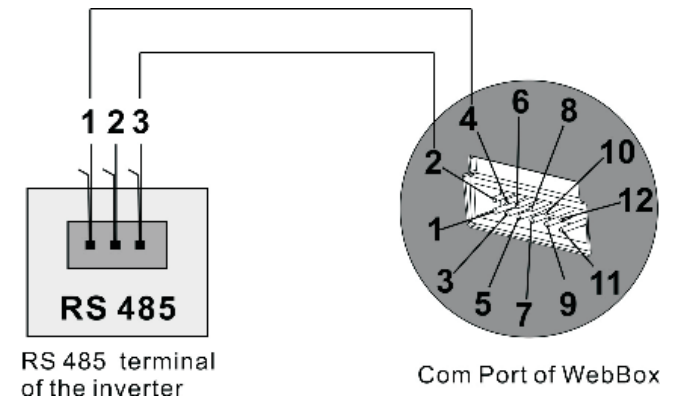

6.5.4 Inverter demand response modes (DRMs,only for Australia)

This series inverter has the function of demand response modes, We use RJ45 socket as inverter DRED connection.

6.5.4.1 Definitions of RJ45 socket pins as follows:

Start-Up and shut down the inverter⁷

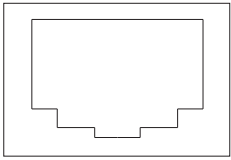
Pin1----- DRM5	
Pin2----- DRM6	
Pin3----- DRM7	
Pin4----- DRM8	
Pin5----- RefGen	
Pin6----- COM/DRM0	
Pin7----- NC	
Pin8----- NC	

6.5.4.2 Definitions of RJ45 plug pins as follows

No. of RJ45 plug	Color of the wires	
1	white and orange	
2	orange	
3	white and green	
4	blue	
5	white and Blue	
6	green	
7	white and brown	
8	brown	

6.5.4.3 Method of asserting demand response modes

MODE	Rj45 socket Asserted by shorting pins		Requirement
DRM0	5	8	Operate the disconnection device
DRM5	1	5	Do not generate power
DRM6	2	5	Do not generate at more than 50% of rated power
DRM7	3	5	Do not generate at more than 75% of rated power AND Sink reactive power if capable
DRM8	4	5	Increase power generation (subject to constraints from other active DRMs)

7.1 Start-Up the inverter

1. Turn on the AC grid breaker;
2. Turn on the DC switch of the inverter, and the inverter will start automatically when the input voltage is higher than 160V.

7.2 Shut down the Inverter

1. Turn off the AC grid breaker;
2. Turn off the DC switch of the inverter.
3. Check the inverter operating status.
4. Until the display of LCD goes out, the inverter is shut down.

8 Maintenance and Cleaning

Once the output power is derating because of too high warming, some tips can help you solve such problems:

- The air grills are clogged. To clean the air grills or heat sink.
- Ventilation of installation location is poor. Choose appropriate installation location before mounting.

8.1 Cleaning the Inverter

If the inverter is dirty, turn-off the AC breaker and DC switch, waiting the inverter shut down, then clean the enclosure lid and the display using only a wet cloth. Do not use any cleaning agents (e.g. solvents or abrasives).

8.2 Checking the DC Disconnect

Check for externally visible damage and discoloration of the DC Disconnect and the cables at regular intervals. If there is any visible damage to the DC Disconnect, or visible discoloration or damage to the cables, contact the installer.

- > Once a year, turn the rotary switch of the DC Disconnect from the "On" position to the "Off" position 5 times in succession. This cleans the contacts of the rotary switch and prolongs the electrical endurance of the DC Disconnect.

9 Trouble shooting

Our quality control program assures that every inverter is manufactured to accurate specifications and is thoroughly tested before leaving our factory. If you have difficulty in the operation of your inverter, please read through the following information to correct the problem.

9.1 Error Messages displayed on LCD

An error message will be displayed on the LCD screen when a fault occurs. The faults consist of system fault and inverter fault.

You may be advised to contact manufacturer in some situation, please provide the following information.

Information concerning the inverter:

- Serial number
- Model number
- Error message on LCD
- Short description of the problem
- Grid voltage
- DC input voltage
- Can you reproduce the failure? If yes, how?
- Has this problem occurred in the past?
- What was the ambient condition when the problem occurred?

Information concerning the PV panels:

- Manufacturer name and model number of the PV panel
- Output power of the panel
- Voc of the panel
- Vmp of the panel
- Imp of the panel
- Number of panels in each string

If it is necessary to replace the unit, please ship it in the original box.

9.2 System fault

System fault (system faults are mainly caused by system instead of inverter, please check the items as instructed below before replacing inverter).

Error message	Description	Suggestion
Error: 124	No AC connection	Check AC wiring. Check the status of AC breaker
PV Isolation Low Error: 125	Insulation problem	1. Check if panel enclosure ground properly. 2. Check if inverter ground properly. 3. Check if the DC breaker gets wet. 4. Check the impedance of PV (+) & PV (-) between ground (must be more than 50 K Ω or 1000 K Ω (VDE 0126)). If the error message is displayed despite the above checking passed, contact Growatt.
Residual I High Error: 126	Leakage current too high	1. Restart the invert. 2. If error message still exists, contact Growatt.
PV Voltage High Error: 128	The DC input voltage is exceeding the maximum tolerable value.	1. Disconnect the DC switch immediately. 2. Check the voltage of each PV string with multimeter. 3. If the voltage of PV string is lower than 1000V, contact Growatt.
Auto Test Failed	Auto test didn't pass.	Restart inverter, repeat Auto Test, if problem still exist, contact Growatt.
AC V Outrange Error: 129	Utility grid voltage is out of permissible range.	Please switch off DC switch. Check AC wiring, especially neutral and ground wire. Check grid voltage is complied with local grid standard. Restart inverter, if problem still exist, Contact Growatt.
AC F Outrange Error: 130	Utility grid frequency out of permissible range.	Please switch off DC switch. Check AC wiring, especially neutral and ground wire. Check grid frequency is complied with local grid standard. Restart inverter, if problem still exist, Contact Growatt.

9.3 Inverter warning

Warning code	Meanings	Suggestion
Warning103	Fail to read EEPROM.	Restart the inverter. If the warning still exist, please contact customer service to replace the COM board.
Warning104	firmware version is not consistent.	Update the right version firmware.
Warning 105	Fail to write EEPROM.	Restart the inverter. If the warning still exist, please contact our customer service to replace the COM board.
Warning 108	PV 1 or PV2 Circuit short	Check the PV panel polarity. Restart the inverter. If the warning still exist, please contact Growatt customer service to replace the POWER board.
Warning 109	PV 1 or PV2 boost broken	Restart the inverter. If the warning still exist, please contact Growatt customer service to replace the power board.

9.4 Inverter fault

Error code	Meanings	Suggestion
Error: 101	Communication board has not received data from control board for 10 seconds.	Restart inverter, if problem still exist, update the firmware; Change control board or COM board, if problem still exist, contact Growatt.
Error: 103	EEPROM fault.	Restart inverter, if problem still exist, Contact Growatt.
Error: 107	The AC voltage sampled by the main MCU and redundant MCU is not the same.	Restart inverter, if problem still exist, Contact Growatt.
Error: 116	Bus sample fault	Restart inverter, if problem still exist, Contact Growatt.
Error: 117	Relay fault.	Restart inverter, if problem still exist, Contact Growatt.

Error: 119	GFCI fault.	Restart inverter, if problem still exist, Contact Growatt.
Error: 120	Current unbalance	Restart inverter, if problem still exist, change power board, or contact Growatt.
Error: 121	Control board has not received data from Communication board for 5S.	Restart inverter, if problem still exist, update the firmware; Change control board or COM board, if problem still exist, contact Growatt.
Error: 122	Bus over voltage	Restart inverter, if problem still exist, Contact Growatt.
Error: 127	Output High DCI	Restart inverter, if problem still exist, Contact Growatt.
Error: 131	Over Temperature	If the ambient temperature of inverter is lower than 60°C, restart inverter, if error message still exists, contact Growatt.

10 Decommissioning

Specification 11

10.1 Dismantling the Inverter

1. Disconnect the inverter as described in section 7.
2. Remove all connection cables from the inverter.



CAUTION Danger of burn injuries due to hot enclosure parts!
Wait 20 minutes before disassembling until the housing has cooled down.

3. Screw off all projecting cable glands.
4. Lift the inverter off the bracket and unscrew the bracket screws.

10.2 Packing the Inverter

If possible, always pack the inverter in its original carton and secure it with tension belts. If it is no longer available, you can also use an equivalent carton. The box must be capable of being closed completely and made to support both the weight and the size of the inverter.

10.3 Disposing of the Inverter



Do not dispose of faulty inverters or accessories together with household waste. Please accordance with the disposal regulations for electronic waste which apply at the installation site at that time. Ensure that the old unit and, where applicable, any accessories are disposed of in a proper manner.

11.1 Specification of TL3-S

Model	3000TL3-S	4000TL3-S	5000TL3-S	6000TL3-S
Specification				
Input data				
Max. DC power	3600W	4800W	6000W	7200W
Max. DC voltage	1000V	1000V	1000V	1000V
Start Voltage	140V	140V	140V	140V
PV voltage range	140V-1000V	140V-1000V	140V-1000V	140V-1000V
MPP voltage range/ DC nominal voltage	200V-1000V /620V			
Full load voltage range	160V-800V	200V-800V	250V-800V	290V-800V
Max. PV Isc	16A/16A	16A/16A	16A/16A	16A/16A
Max. input current	11A/11A	11A/11A	11A/11A	11A/11A
Backfeed current	0A	0A	0A	0A
Number of independent MPP trackers/strings per MPP tracker	2/1+1	2/1+1	2/1+1	2/1+1
Output (AC)				
Rated AC output power	3kW	4kW	5kW	6kW
Max AC apparent power	3kVA	4kVA	5kVA	6kVA
Max. output current	4.5A	6.1A	7.6A	9.1A
Inrush current	<15A	<15A	<15A	<15A
Max output fault current	22A	22A	22A	22A
Max output overload protection	10A	10A	16A	16A
Nominal AC voltage	230V/400V	230V/400V	230V/400V	230V/400V
Nominal AC voltage range	310~476V	310~476V	310~476V	310~476V
AC grid frequency	50/60Hz	50/60Hz	50/60Hz	50/60Hz
AC grid frequency range	44-55Hz/54-65Hz			

Power factor at rated power	1	1	1	1
Adjustable displacement power factor	0.8leading - 0.8lagging			
THDi @Full load&THDv<1%	<3%	<3%	<3%	<3%
AC grid connection type	3W+N+PE	3W+N+PE	3W+N+PE	3W+N+PE
Efficiency				
Max efficiency	98.0%	98.0%	98.0%	98.0%
Euro-eta	96.5%	96.7%	96.9%	97.1%
MPPT efficiency	99.5%	99.5%	99.5%	99.5%
Protection devices				
DC reverse polarity protection	yes	yes	yes	yes
DC switch for each MPPT	yes	yes	yes	yes
Output AC overcurrent protection	yes	yes	yes	yes
Output AC overvoltage Protection - Varistor	yes	yes	yes	yes
Ground fault monitoring	yes	yes	yes	yes
Grid monitoring	yes	yes	yes	yes
Integrated all-pole sensitive leakage current monitoring unit	yes	yes	yes	yes
General Data				
Dimensions(W/H/D) in mm	480*448*200			
Weight	21.2kg			
Operating temperature range	-25 °C ... +60 °C (-13 °F ... +140 °F) With derating above 45 °C(113 °F)			
Noise emission (typical)	≤ 35 dB(A)			
Altitude	3000m			

Self-consumption night	<0.5 W
Topology	transformerless
Cooling concept	Natural convection
Environmental Protection Rating	IP 65
Relative humidity	0...100%
Features	
DC connection	H4/MC4(opt)
AC connection	Screw terminal
Display	LCD
Interfaces: RS232/RS485/GPRS /RF/Wifi	yes/yes/opt/opt /opt
Warranty: 5 years / 10 years	yes /opt
Certificates and approvals	EN61000-6-2,EN61000-6-3,EN61000-3-2,EN61000-3-3, IEC62109-1,IEC62109-2,CE,VDE0126,NB/T32004-2013

Model	7000TL3-S	8000TL3-S	9000TL3-S
Specification			
Input data			
Max. DC power	8400W	9600W	10800W
Max. DC voltage	1000V	1000V	1000V
Start Voltage	160V	160V	160V
PV voltage range	160V-1000V	160V-1000V	160V-1000V
MPP voltage range/ DC nominal voltage	200V-1000V /600V		
Full load voltage range	320V-850V	360V-850V	400V-850V
Max. PV Isc	16A/16A	16A/16A	16A/16A
Max. input current	11.5A/11.5A	11.5A/11.5A	11.5A/11.5A
Backfeed current	0A	0A	0A
Number of independent MPP trackers/strings per MPP tracker	2/1+1	2/1+1	2/1+1
Output (AC)			
Rated AC output power	7kW	8kW	9kW
Max AC apparent power	7.7kVA	8.8kVA	9.9kVA
Max. output current	11.7A	13.3A	15A
Inrush current	<15A	<15A	<15A
Max output fault current	33A	33A	33A
Max output overload protection	16A	20A	25A
Nominal AC voltage	230V/400V	230V/400V	230V/400V
Nominal AC voltage range	310~476V	310~476V	310~476V
AC grid frequency	50/60Hz	50/60Hz	50/60Hz
AC grid frequency range	44-55Hz/54-65Hz		

Power factor at rated power	1	1	1
Adjustable displacement power factor	0.8leading - 0.8laging		
THDi @Full load&THDv<1%	<3%	<3%	<3%
AC grid connection type	3W+N+PE	3W+N+PE	3W+N+PE
Efficiency			
Max efficiency	98.3%	98.3%	98.3%
Euro-eta	97.5%	97.8%	98%
MPPT efficiency	99.5%	99.5%	99.5%
Protection devices			
DC reverse polarity protection	yes	yes	yes
DC switch for each MPPT	yes	yes	yes
Output AC overcurrent protection	yes	yes	yes
Output AC overvoltage Protection - Varistor	yes	yes	yes
Ground fault monitoring	yes	yes	yes
Grid monitoring	yes	yes	yes
Integrated all-pole sensitive leakage current monitoring unit	yes	yes	yes
General Data			
Dimensions(W/H/D) in mm	480*448*200		
Weight	22kg		
Operating temperature range	-25 °C ... +60 °C (-13 °F ... +140 °F) With derating above 45 °C(113 °F)		
Noise emission (typical)	≤ 35 dB(A)		
Altitude	3000m		

Self-consumption night	<0.5 W
Topology	transformerless
Cooling concept	Natural convection
Environmental Protection Rating	Ip65
Relative humidity	0...100%
Features	
DC connection	H4/MC4(opt)
AC connection	Screw terminal
Display	LCD
Interfaces: RS232/RS485/GPRS /RF/Zigbee/Wifi	yes/yes/opt/opt /opt/opt
Warranty: 5 years / 10 years	yes /opt
Certificates and approvals	EN61000-6-2,EN61000-6-3,EN61000-3-2,EN61000-3-3, IEC62109-1,IEC62109-2,CE,VD0126,NB/T32004-2013

Model	10000TL3-S	11000TL3-S	12000TL3
Specification			
Input data			
Max. DC power	12000W	14400W	14400W
Max. DC voltage	1000V	1000V	1100V
Start Voltage	160V	160V	160V
PV voltage range	160V-1000V	160V-1000V	160V-1000V
MPP voltage range/ DC nominal voltage	200V-1000V /600V		
Full load voltage range	450V-850V	450V-850V	550V-850V
Max. PV Isc	16A/16A	16A/16A	16A/16A
Max. input current	13A/13A	13A/13A	11.5A/11.5A
Backfeed current	0A	0A	0A
Number of independent MPP trackers/strings per MPP tracker	2/1+1	2/1+1	2/1+1
Output (AC)			
Rated AC output power	10kW	11kW	12kW
Max AC apparent power	11kVA	12.1kVA	13.2kVA
Max. output current	16.7A ^(note 1)	18.3A	19A
Inrush current	<15A	<15A	<15A
Max output fault current	33A	33A	44A
Max output overload protection	25A	25A	25A
Nominal AC voltage	230V/400V	230V/400V	230V/400V
Nominal AC voltage range	310~476V	310~476V	310~476V
AC grid frequency	50/60Hz	50/60Hz	50/60Hz
AC grid frequency range	44-55Hz/54-65Hz		

Power factor at rated power	1	1	1
Adjustable displacement power factor	0.8leading - 0.8lagging		
THDi @Full load&THDv<1%	<3%	<3%	<3%
AC grid connection type	3W+N+PE	3W+N+PE	3/N/PE
Efficiency			
Max efficiency	98.3%	98.3%	98.3%
Euro-eta	98%	98%	97.8%
MPPT efficiency	99.5%	99.5%	99.5%
Protection devices			
DC reverse polarity protection	yes	yes	yes
DC switch for each MPPT	yes	yes	yes
Output AC overcurrent protection	yes	yes	yes
Output AC overvoltage Protection - Varistor	yes	yes	yes
Ground fault monitoring	yes	yes	yes
Grid monitoring	yes	yes	yes
Integrated all-pole sensitive leakage current monitoring unit	yes	yes	yes
General Data			
Dimensions(W/H/D) in mm	480*448*200		
Weight	22kg	22kg	23.5kg
Operating temperature range	-25 °C ... +60 °C (-13 °F ... +140 °F) With derating above 45 °C(113 °F)		
Noise emission (typical)	≤ 35 dB(A)		
Altitude	3000m		

Self-consumption night	<0.5 W
Topology	transformerless
Cooling concept	Natural convection
Environmental Protection Rating	Ip65
Relative humidity	0...100%
Features	
DC connection	H4/MC4(opt)
AC connection	Screw terminal
Display	LCD
Interfaces: RS232/RS485/GPRS /RF/Zigbee/Wifi	yes/yes/opt/opt /opt/opt
Warranty: 5 years / 10 years	yes /opt
Certificates and approvals	EN61000-6-2,EN61000-6-3,EN61000-3-2,EN61000-3-3, IEC62109-1,IEC62109-2,CE,VDE0126,NB/T32004-2013
Note 1:Max. output current of Growatt 10000TL3-S is 15. 9A for UK market.	

Model	12000TL3-S	13000TL3-S	15000TL3-S
Specification			
Input data			
Max. DC power	14400W	15600W	18000W
Max. DC voltage	1100V	1100V	1100V
Start Voltage	160V	160V	160V
PV voltage range	160V-1000V	160V-1000V	160V-1000V
MPP voltage range/ DC nominal voltage	200V-1000V /600V		
Full load voltage range	480V-850V	480V-850V	520V-850V
Max. PV Isc	16A/16A	16A/16A	16A/16A
Max. input current	20A/10A	20A/10A	20A/10A
Backfeed current	0A	0A	0A
Number of independent MPP trackers/strings per MPP tracker	2/2+1	2/2+1	2/2+1
Output (AC)			
Rated AC output power	12kW	13kW	15kW
Max AC apparent power	13.2kVA	14.3kVA	16.5kVA
Max. output current	19A	20.6A	23.8A
Inrush current	<15A	<15A	<15A
Max output fault current	44A	44A	44A
Max output overload protection	25A	32A	32A
Nominal AC voltage	230V/400V	230V/400V	230V/400V
Nominal AC voltage range	310~476V	310~476V	310~476V
AC grid frequency	50/60Hz	50/60Hz	50/60Hz
AC grid frequency range	44-55Hz/54-65Hz		

Power factor at rated power	1	1	1
Adjustable displacement power factor	0.8leading - 0.8laging		
THDi @Full load&THDv<1%	<3%	<3%	<3%
AC grid connection type	3W+N+PE	3W+N+PE	3W+N+PE
Efficiency			
Max efficiency	98.3%	98.3%	98.3%
Euro-eta	98%	98%	98%
MPPT efficiency	99.5%	99.5%	99.5%
Protection devices			
DC reverse polarity protection	yes	yes	yes
DC switch for each MPPT	yes	yes	yes
Output AC overcurrent protection	yes	yes	yes
Output AC overvoltage Protection - Varistor	yes	yes	yes
Ground fault monitoring	yes	yes	yes
Grid monitoring	yes	yes	yes
Integrated all-pole sensitive leakage current monitoring unit	yes	yes	yes
General Data			
Dimensions(W/H/D) in mm	480*448*200		
Weight	23.5kg		
Operating temperature range	- 25 °C ... +60 °C (-13 °F ... +140 °F) With derating above 45 °C(113 °F)		
Noise emission (typical)	≤ 35 dB(A)		
Altitude	3000m		

Self-consumption night	<0.5 W
Topology	transformerless
Cooling concept	Natural convection
Environmental Protection Rating	Ip65
Relative humidity	0...100%
Features	
DC connection	H4/MC4(opt)
AC connection	Screw terminal
Display	LCD
Interfaces: RS232/RS485/GPRS /RF/Zigbee/Wifi	yes/yes/opt/opt /opt/opt
Warranty: 5 years / 10 years	yes /opt
Certificates and approvals	EN61000-6-2,EN61000-6-3,EN61000-3-2,EN61000-3-3, IEC62109-1,IEC62109-2,CE,VDE0126,NB/T32004-2013

11.2 DC connector info

DC connector Specification:

Contact size	4mm²/12 AWG
Rated current(at 90 C)	30A
Rated system voltage	1000V DC(TUV)
Contact resistance	0.25mΩ TYP
Degree of protection(mated)	Ip67
Socket contact material	Copper. Tin plated
Insulation material	PC, UL94 V-0
Ambient temperature range	-40°C to +90°C
Strip length	7.0mm(9/32)
Cable jacket diameter	4.5 to 7.8mm(3/16: to 5/16")

11.3 Torque Values

Enclosure lid screws	0.7Nm(6.2 lbf.in)
Shell and RS232 screws	0.7Nm(6.2 lbf.in)
AC terminal	0.6Nm(5.2 lbf.in)
M6 socket head cap screws for securing the enclosure at the bracket	2Nm(18 lbf.in)
Additional ground screws	2Nm(18lbf.in)

11.4 Spare Parts and Accessories

In the following table you will find the optional accessories for your product. If required, you can order these from SHENZHEN GROWATT NEW ENERGY TECHNOLOGY CO., LTD or your dealer.

Name	Description	Growatt order number
ShineLAN	Communication interface	MR00.0003100
Wi-Fi	Communication interface	MR00.0001402
Shine WebBox	Communication data logger	MR00.0001700
Shine Vision receiver	Communication data logger receiver	MR00.0000201
Shine Vision emitter	Communication data logger emitter	MR00.0000601

12.1 DC connector info

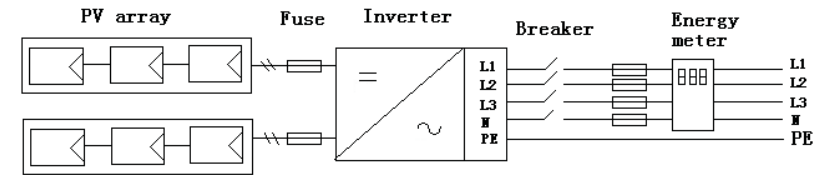

12.2 Multi inverters

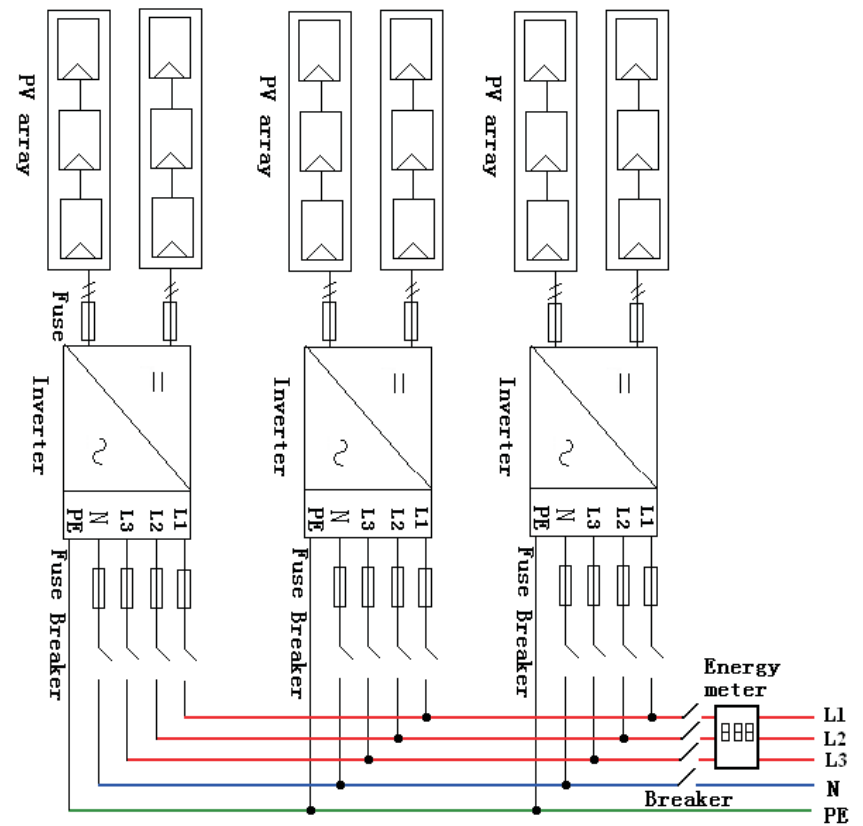

13 Certificates

TL3-S series is designed to use worldwide, hence the inverters meet different safety standards of variety countries and regions.

Model	Certificates
3000-15000TL3-S	CE ,VDE0126-1-1, N4105,IEC 62109 ,AS4777,CEC,IEC61727, IEC62116,EN50438,IEC60068,IEC61683,CEI 0-21,G83,G59

14 Contact

If you have technical problems concerning our products, contact your installer or manufacturer. During inquiring, please provide below information:

1. Inverter type
2. Modules information
3. Communication method
4. Serial number of Inverters
5. Error code of Inverters
6. Display of inverter

Shenzhen Growatt New Energy Technology CO.,LTD

No.28 Guangming Road, Longteng Community, Shiyan,
Bao'an District, Shenzhen, P.R.China

T + 86 755 2747 1942

E service@ginverter.com

W www.ginverter.com