

GBLI6532 Battery System Quick Installation Guidance



CAUTION

- * Ensure to read the Guidance before installation in order to understand product information and safety precautions.
- * Operators should be well trained to fully understand grid-connected photovoltaic power system and national/regional standards.
- * Installers must use insulating tools and wear safety equipment.
- * Device damages caused noncompliance with storage, transportation, installation and usage requirements specified in Quick Guidance and Manual are not covered by Warranty.

1 Product Overview

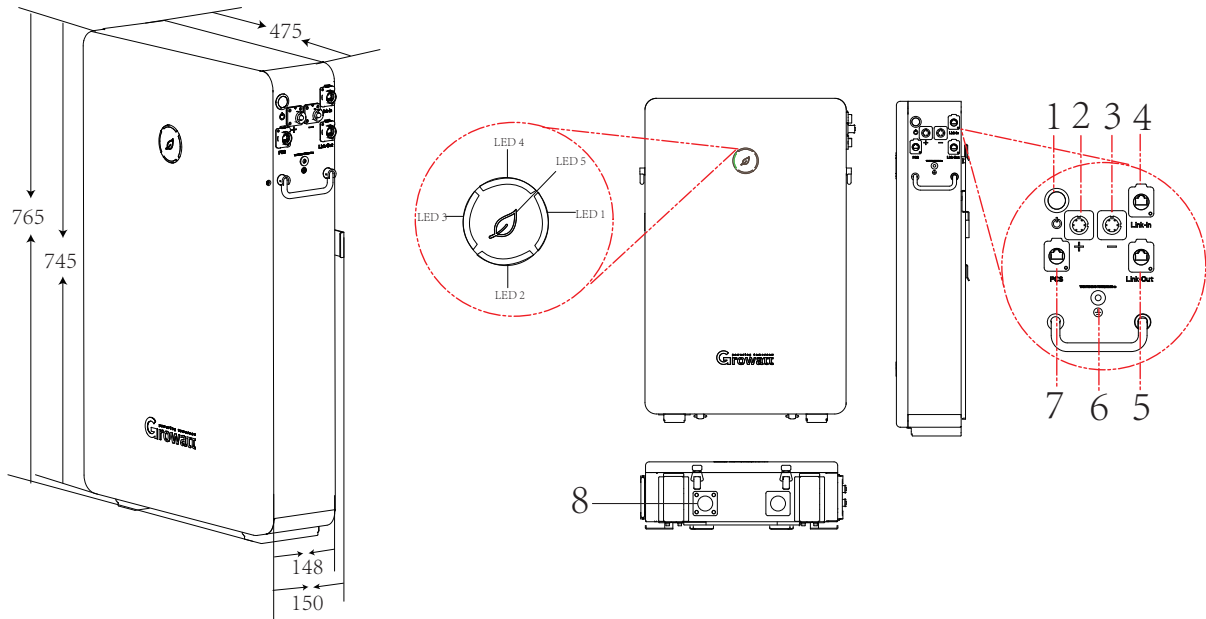

No.	label	Name	No.	label	Name
1	POWER	Power button	5	Link-out	Parallel Network Output
2	+	Positive terminal	6	⊕	Grounding terminal
3	-	Negative terminal	7	PCS	Network port to PCS
4	Link-In	Parallel Network Input	8	Safety vent	A vent to release pressure inside.

2 Installation Process

2.1 Installation Location Requirements

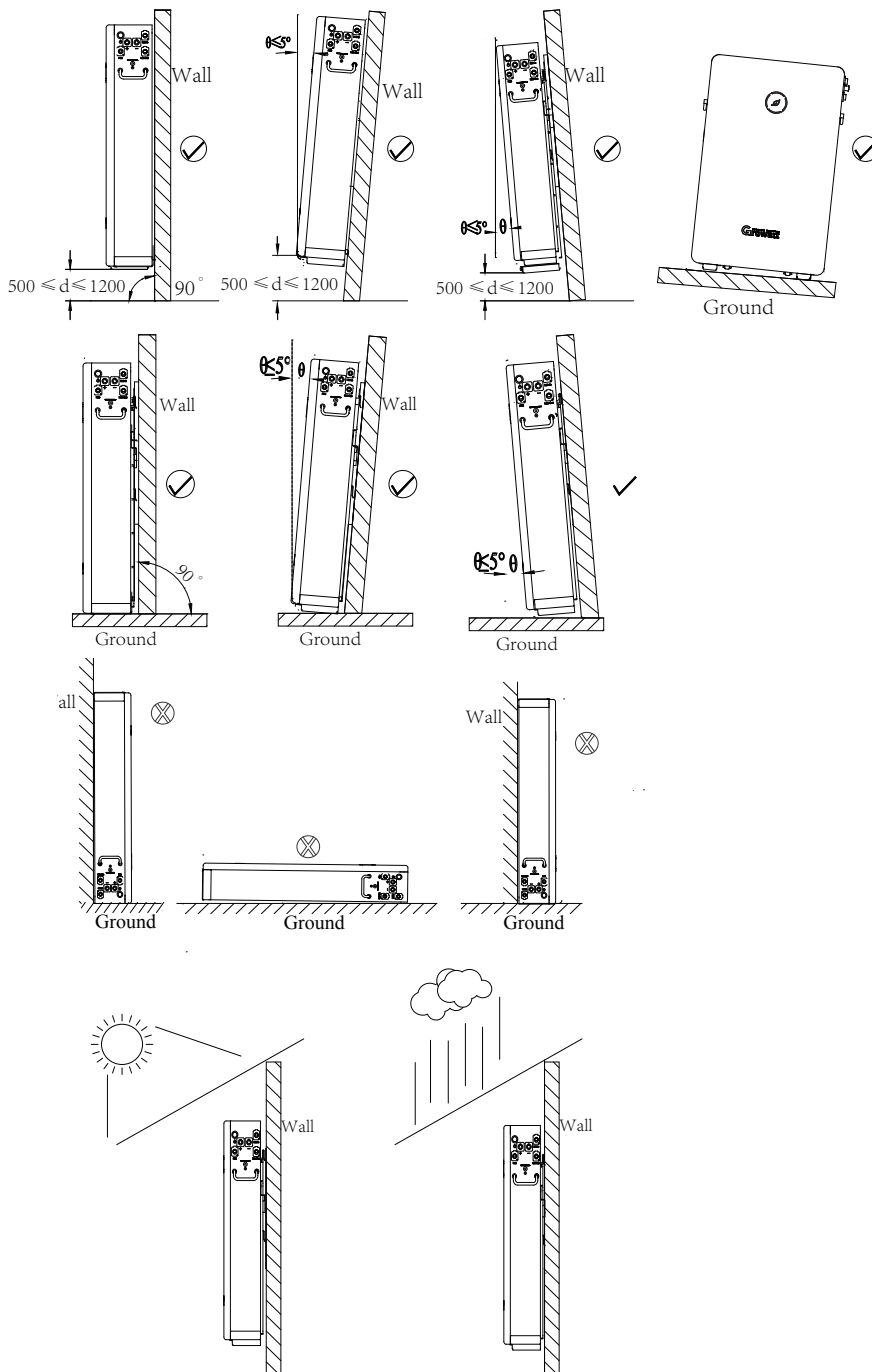

CAUTION

- * A manually operating breaker should be installed between battery and PCS to control the main circuit under installation, wire connection and maintenance mode. The breaker can be operated manually without using any tool. The distance between battery and the breaker should comply with local regulations.
- * Do not install or use battery near explosive or inflammable substances.
- * Use battery in well-ventilated environment with temperature ranging from -10°C to 50°C .
- * For outdoor installation, build sun & rain shade to avoid direct sunlight and rain exposure.
- * Do not place battery upside down nor alongside as the above picture shown.
- * Maintain a minimum level of dust and dirt in the environment.

- * Do not install battery in highly humid area such as bathroom.
- * Ensure two batteries in parallel connection are from the same batch, same model and same manufacturer. Do not mix old battery with new battery. Batteries with no more than 300 cycles are defined as new batteries.

2.2 Wall Mountable Installation

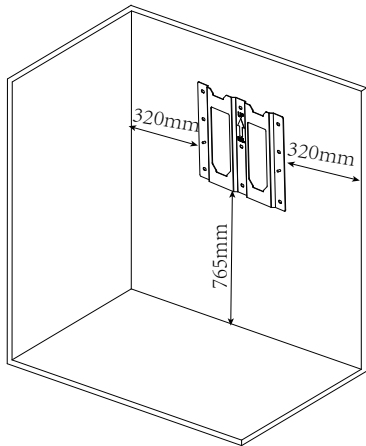

Step 1: Put bracket on wall and mark drilling spots

Note:

1. Keep a minimal distance of 320mm between wall and bracket; a maximum distance of 765mm between bracket and ground. Leave a minimum clearance of 133mm before the front surface of battery.
2. The weight capacity of wall should exceed 4 times weight of batteries.
3. At least two persons conduct the installation. One person places the bracket on wall and ensure the gradient horizontal; the other person marks four spots of screw driving.

Step 2: Drill in the spots for at least 60mm. Clean the soil and drive expansion tube into the hole.

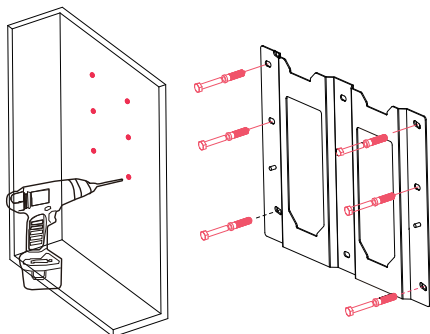

Proposal 1

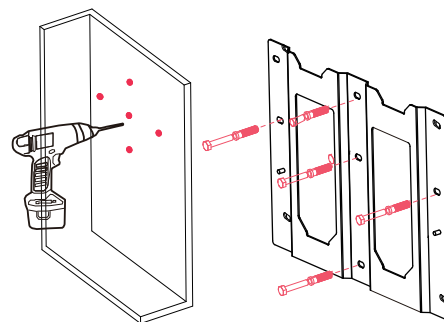

Proposal 2

Note:

1. Choose alloy drill bit with a diameter of 12mm.
2. One person puts the bracket on wall and minds to keep gradient horizontal. The other person drives M8 screw through the bracket into holes.



CAUTION

There are two spot drilling proposals available.

For installation on a wall with its main supporting beams at a distance of 16 inches, it is recommended to adopt the first drilling spots.

For wall with its main supporting beam at a distance of 24 inches, it is recommended to adopt the second drilling spots.

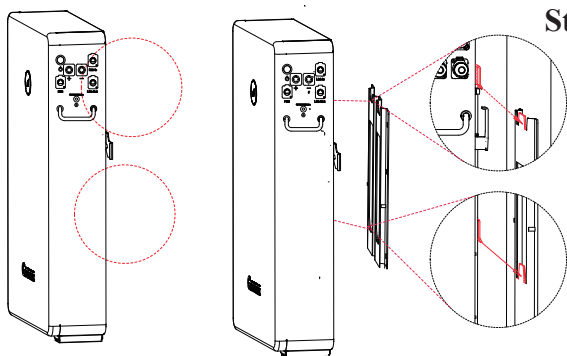

Step 3: Fix battery on bracket from the top down.

Note:

In order to guarantee a stable connect between battery and bracket, please visually check if the two upper joints are fixed. Try to move the lower part of battery away from wall. The connection is proved qualified if the battery cannot be moved at all. Otherwise, please connect the battery and bracket again until confirming a fixed connect.

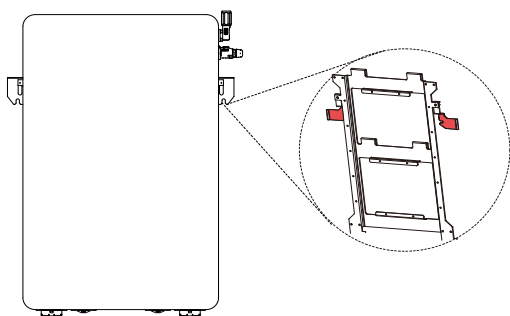

Step 4: Rotate the left latch rightward until the notch locks limiting pin, rotate the right latch leftward until the notch locks limiting pin too.

2.3 Floor Standing Installation

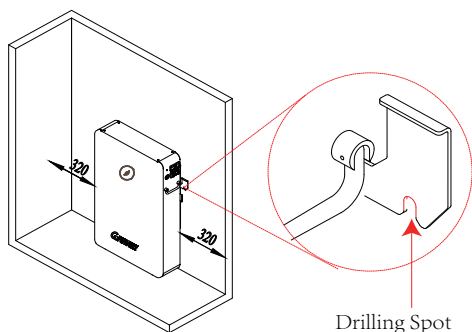

Step 1: Place battery in the to-be-installed area and mark two drilling spots.

Note:

1. Keep a minimum distance of 320mm between wall and battery.
2. Leave a minimum clearance of 133mm before the front surface of battery.

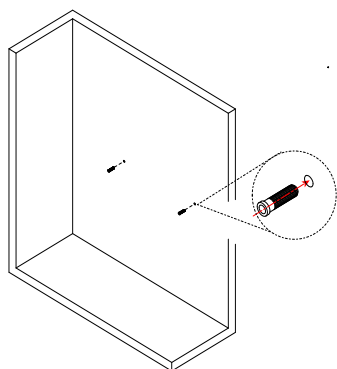

Step 2: Drill in the spots for at least 60mm. Clean the soil and drive expansion tube into hole.

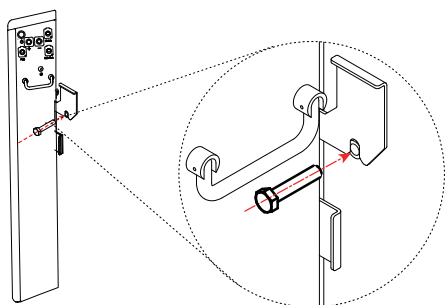

Drive M8 screw through notch of latch into wall.

3 Electrical Connection

Communication interface definition:

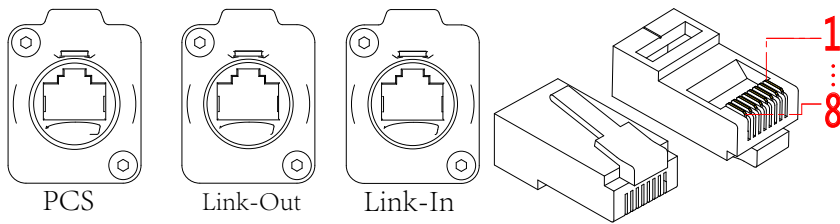

Item	No.	Definition	Item	No.	Definition	Item	No.	Definition
PCS	1	PCS-RS485-B	Link-Out	1	COM-CANH	Link-In	1	COM-CANH
	2	PCS-RS485-A		2	COM-CANL		2	COM-CANL
	3	GND-ISO		3	Encode-OUT+		3	Encode-IN+
	4	PCS=CANH		4	GND-ISO		4	GND-ISO
	5	PCS=CANL		5	Slave-Last		5	Master-Select
	6	GND-ISO		6	GND-ISO		6	GND-ISO
	7	PCS-WAKE-		7	GND-ISO		7	GND-ISO
	8	PCS-WAKE+		8	WKP-OUT+		8	WKP-OUT+

3.1 Connect Cables for Single Battery

1. Measure battery voltage with a multi-meter and ensure the voltage output is 0V under power off mode.
2. Fasten grounding terminal and grounding cable with M6 screw (recommending a torque of 5N.m).

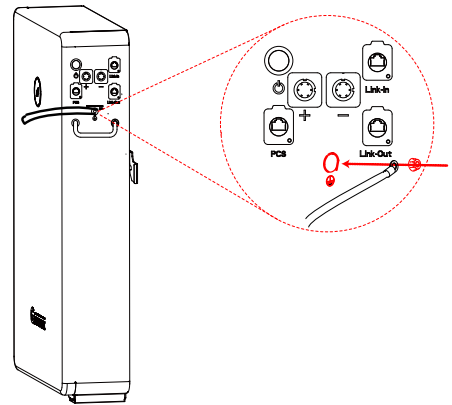

3. Insert power cables into DC Breaker and battery terminals (orange positive cable and black negative cable); Plug one end of Network Cable A into battery port (lablling as PCS) and the other end into PCS.

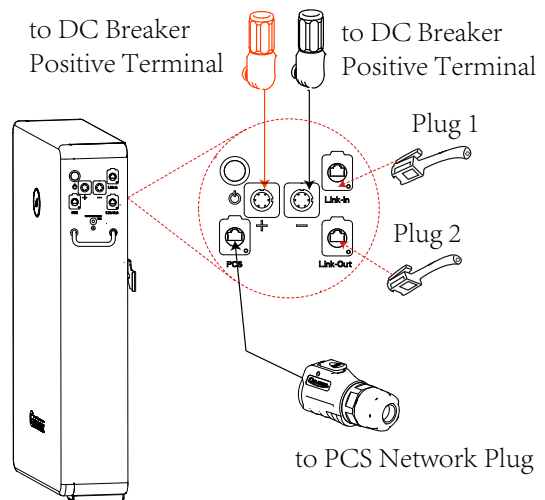

3.2 Connect Cables for Parallel-connected Batteries

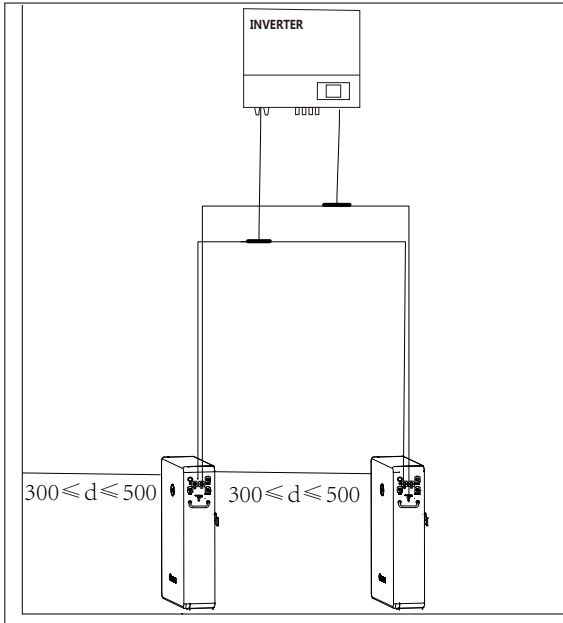

1. Install Batteries
Power on each battery in condition of no load, measure the voltages with a multi-meter and confirm voltage difference less than 1V. Power off the batteries. Keep the distance among battery, DC Breaker and PCS as shown. (unit: mm)

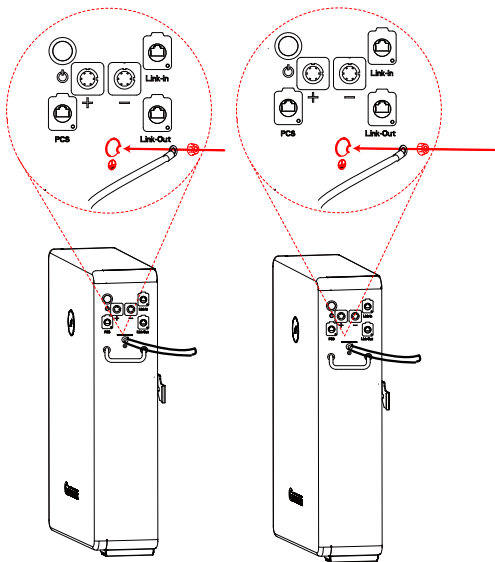

2. Fasten ground terminal and grounding cable with M6 screw for two batteries.

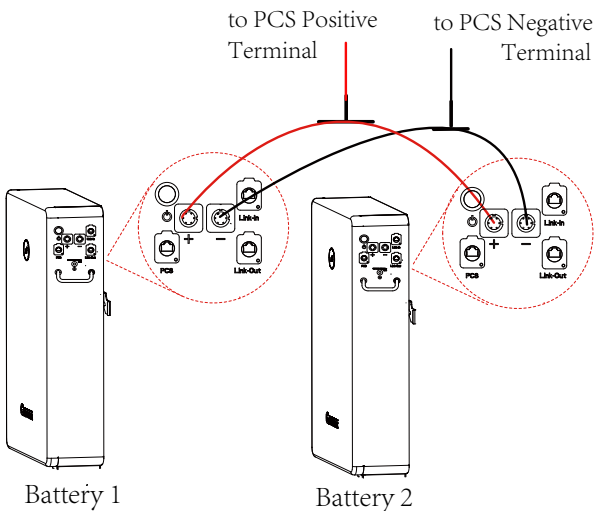

3. Insert power cables
Plug one end of power cables into DC breaker. Measure the positive and negative terminal blocks of each battery with a multi-meter and ensure the voltage outputs under off mode are all 0V. After that, plug the other end of power cables into battery terminals.

4. Insert network cables

Network Cable A is defined as the cable connecting PCS and Battery 1, Network Cable B as the cable connecting two batteries. Two cables are made based on the pin definition as shown in Section 3. The other end of Network Cable A will be made according to the PCS specifications. Two plug are used to define master battery and slave batteries.

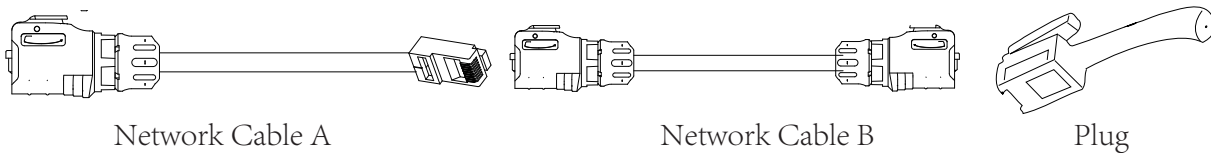

Connect two batteries with Network Cable B, and connect battery and PCS with Network Cable A. Insert one plug into the Link-In of Battery 1 and other plug into the Link-Out of Battery 2.

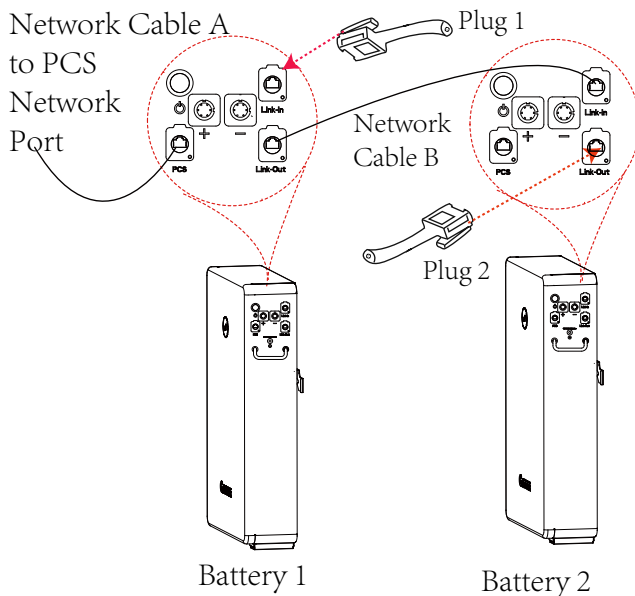

CAUTION

Two plugs (shown as plug1 and plug 2) are exactly the same and can be mixed. If the voltage difference is measured more than 1V, the difference shall be adjusted to be no more than 1V either by charging the battery with lower voltage or discharging the battery with higher voltage before conducting the parallel connected installation; Please press the POWER button of any battery to turn on/off system under parallel connection.

5 Power on/off Battery

CAUTION

- * Technical knowledge is involved in the electrification process, and electricians must go through technical training and obtain certificates in compliance with local law and regulations.
- * Please stand on dry insulating objects and do not wear metal objects such as watches, necklaces and rings during operation. Insulating tools should be used.
- * Do not contact with two charged positions with potential difference.
- * Make sure that the PCS is turned off before checking battery.

5.1 Power on Battery

Single Battery			
Power on battery by pressing POWER button		Power on battery by Activating PCS	
Procedures	Acceptation criteria	Procedures	Acceptation criteria
1 Close the breaker from battery to converter.	Breaker in ON status.	1 Close the breaker from battery to converter.	Breaker in ON status.
2 Press POWER button for two seconds and observe the LED indication on panel.	If both RUN and SOC lights turn on normal. Battery powers on successfully; If ALM light turns red, there is a failure and should fix before power on again.	2. PV or AC powers PCS.	PCS in ON status; PCS HMI screen indicates normal PV or mains supply input.
		3. PCS voltage signal activates battery.	If RUN light and SOC lights on battery indicate normal, and battery powers on successfully; If the ALM light turns red, the indication shows a failure. The failure shall be fixed before powering on again.
Parallel Connection			
Power on parallel connected Batteries by pressing POWER button		Power on parallel connected Batteries by Activating PCS	
Procedures	Acceptation criteria	Procedures	Acceptation criteria
1 Close the breaker from battery to converter.	Breaker in ON status.	1 Close the breaker from battery to converter.	Breaker in ON status.
2. Press POWER buttons of any battery for two seconds and observe the LED indication on panel.	If RUN and SOC lights on both batteries turn on normal, and the RUN lights on both batteries flicker for five times, two batteries power on successfully and communication between batteries works; If ALM light of one or both batteries turn red, there is a parallel failure and should be fixed before power on again.	2. PV or AC powers PCS.	PCS in ON status; PCS HMI screen indicates normal PV or mains supply input.

5.2 Power off Battery

- * Press the POWER button of any battery for two seconds. Five LED lights will flicker for three times, and battery turns off.
- * Battery will turn off 25 minutes after Network Cable A connection between PCS and PACK fails.

T: +86 0755 2747 1942
E: service@ginverter.com
W: www.ginverter.com
Address: No.28 Guangming Road,
Shiyan Street, Bao'an District,
Shenzhen, P.R. China